

M **WILHELMOSEN A/S**



SVEJSELEDHOVEDER

Århus

86 150 111

Herlev

44 52 13 52

Vejle

75 820 288

Hydraulik-Gelenkköpfe

wartungspflichtig

Gleitpaarung: Stahl/Stahl

DIN ISO 12 240-4-Maßreihe E,

Form S

Material: ST 52-3

Hydraulic rod ends

requiring maintenance

sliding surface: steel/steel

DIN ISO 12 240-4-series E,

form S

material: ST 52-3

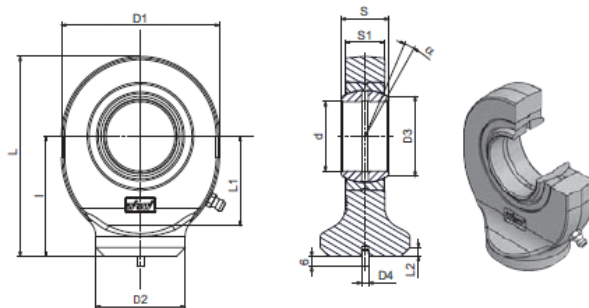

Serie/Series WS·C (GK·DO, SC·ES)

Bezeichnung/Designation	Abmessung/Dimensions mm								
	d	S	l	D ₁	D ₂	S ₁	L	L ₁	L ₂
WS10C*	10 -0,008	9 -0,12	24	29	15	7	38,5	15	2
WS12C*	12 -0,008	10 -0,12	27	34	17,5	8	44	18	2
WS15C**	15 -0,008	12 -0,12	31	40	21	10	51	20	2,5
WS16C**	16 -0,008	14 -0,12	35	46	24	11	58	23	3
WS17C**	17 -0,008	14 -0,12	35	46	24	11	58	23	3
WS20C	20 -0,010	16 -0,12	38	53	27,5	13	64,5	27,5	3
WS25C	25 -0,010	20 -0,12	45	64	33	17	77	33	4
WS30C	30 -0,010	22 -0,12	51	73	40	19	87,5	37	4
WS35C	35 -0,012	25 -0,12	61	82	47	21	102	42	4
WS40C	40 -0,012	28 -0,12	69	92	52	23	115	48	5
WS45C	45 -0,012	32 -0,12	77	102	58	27	128	52	5
WS50C	50 -0,012	35 -0,12	88	112	62	30	144	60	6
WS60C	60 -0,015	44 -0,15	100	135	70	38	167,5	72,5	8
WS70C	70 -0,015	49 -0,15	115	160	80	42	195	86	10
WS80C	80 -0,015	55 -0,15	141	180	95	47	231	98	10

M. Wilhelmsen A/S

Århus

Herlev

Vejle

86 150 111

44 52 13 52

75 820 288

Hydraulik-Gelenkköpfe

wartungspflichtig

Gleitpaarung: Stahl/Stahl

DIN ISO 12 240-4-Maßreihe E,

Form S

Material: ST 52-3

Hydraulic rod ends

requiring maintenance

sliding surface: steel/steel

DIN ISO 12 240-4-series E,

form S

material: ST 52-3

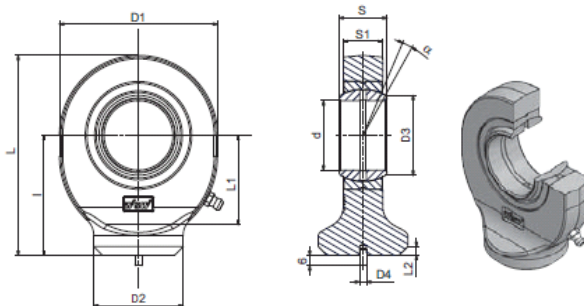

D ₃	D ₄	Kippwinkel/ tilting angle $\alpha^\circ \approx$	Tragzahlen/ Basic load ratings [kN]		Radiale Lagerluft/ Radial internal clearance	Gewicht/ Weight \approx kg	d
			Dyn./Dynamic	Stat./Static	CN		
13,2	3	12	8,15	15,6	0,023 - 0,068	0,040	10
15	3	11	10,8	21,6	0,023 - 0,068	0,070	12
18,4	4	8	17	32	0,030 - 0,082	0,120	15
20,7	4	9	19	36	0,030 - 0,082	0,170	16
20,7	4	10	21,2	40	0,030 - 0,082	0,180	17
24,1	4	9	30	54	0,030 - 0,082	0,260	20
29,3	4	7	48	72	0,037 - 0,100	0,460	25
34,2	4	6	62	95	0,037 - 0,100	0,680	30
39,7	4	6	80	125	0,037 - 0,100	1,03	35
45	4	7	100	156	0,043 - 0,120	1,40	40
50,7	6	7	127	208	0,043 - 0,120	1,98	45
56	6	6	156	250	0,043 - 0,120	2,76	50
66,8	6	6	245	390	0,043 - 0,120	4,67	60
77,8	6	6	315	510	0,055 - 0,142	7,02	70
89,4	6	6	400	620	0,055 - 0,142	11,09	80

M. Wilhelmsen A/S

Århus

Herlev

Vejle

86 150 111

44 52 13 52

75 820 288

Hydraulik-Gelenkköpfe

wartungspflichtig
Gleitpaarung: Stahl/Stahl
Material: ST 52-3

Hydraulic rod ends

requiring maintenance
sliding surface: steel/steel
material: ST 52-3

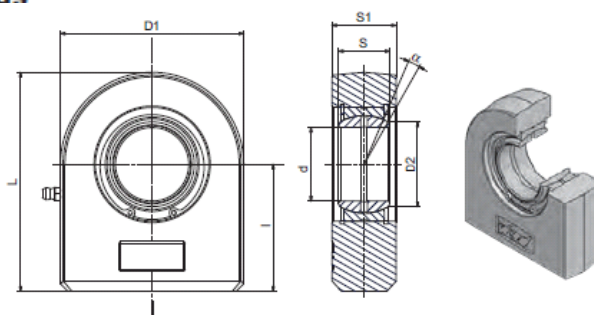

Serie/Series WS·N (GF·DO, SCF·ES)

Bezeichnung/Designation	Abmessung/Dimensions mm							Kippwinkel/ tilting angle $\alpha^{\circ} \approx$
	d	S	l	D ₁	S ₁	D ₂	L	
WS15N	15 -0,008	12 -0,12	31	45	16	18,4	53,5	8
WS16N	16 -0,008	14 -0,12	35	48	17,5	20,7	59	10
WS17N	17 -0,008	14 -0,12	35	48	17,5	20,7	59	10
WS20N	20 -0,010	16 -0,12	38	50	19	24,1	63	9
WS25N	25 -0,010	20 -0,12	45	55	23	29,3	72,5	7
WS30N	30 -0,010	22 -0,12	51	65	28	34,2	83,5	6
WS35N	35 -0,012	25 -0,12	61	83	30	39,7	102,5	6
WS40N	40 -0,012	28 -0,12	69	100	35	45	119	7
WS45N	45 -0,012	32 -0,12	77	110	40	50,7	132	7
WS50N	50 -0,012	35 -0,12	88	123	40	56	149,5	6
WS60N	60 -0,015	44 -0,15	100	140	50	66,8	170	6
WS70N	70 -0,015	49 -0,15	115	164	55	77,8	197	6
WS80N	80 -0,015	55 -0,15	141	180	60	89,4	231	6
WS90N	90 -0,020	60 -0,20	150	226	65	98,1	263	5
WS100N	100 -0,020	70 -0,20	170	250	70	109,5	295	7
WS110N	110 -0,020	70 -0,20	185	295	80	121,2	332,5	6
WS120N	120 -0,020	85 -0,20	210	360	90	135,5	390	6

M. Wilhelmsen A/S

Århus

Herlev

Vejle

86 150 111

44 52 13 52

75 820 288

Hydraulik-Gelenkköpfe

wartungspflichtig
Gleitpaarung: Stahl/Stahl
Material: ST 52-3

Hydraulic rod ends

requiring maintenance
sliding surface: steel/s
material: ST 52-3

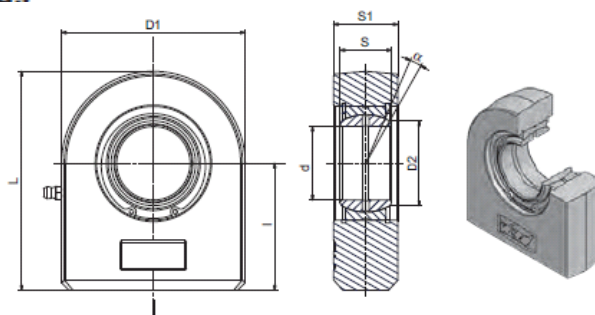

Tragzahlen/ Basic load ratings [kN]		Radiale Lagerluft/ Radial internal clearance	Gewicht/ Weight ≈ kg	d
Dyn./Dynamic	Stat./Static	CN		
17	53	0,030 - 0,082	0,230	15
21,2	59	0,030 - 0,082	0,300	16
21,2	65	0,030 - 0,082	0,300	17
30	67	0,030 - 0,082	0,350	20
48	69,5	0,037 - 0,100	0,530	25
62	118	0,037 - 0,100	0,850	30
80	196	0,037 - 0,100	1,50	35
100	305	0,043 - 0,120	2,42	40
127	386	0,043 - 0,120	3,39	45
156	441	0,043 - 0,120	4,24	50
245	570	0,043 - 0,120	7,10	60
315	724	0,055 - 0,142	10,70	70
400	804	0,055 - 0,142	15,10	80
490	1340	0,055 - 0,142	23,40	90
610	1510	0,065 - 0,165	33,40	100
655	2340	0,065 - 0,165	48,50	110
950	3210	0,065 - 0,165	79,50	120

M. Wilhelmsen A/S

Århus

Herlev

Vejle

86 150 111

44 52 13 52

75 820 288

Hydraulik-Gelenkköpfe

wartungspflichtig
Gleitpaarung: Stahl/Stahl
Material: St 52-3

Hydraulic rod ends

requiring maintenance
sliding surface: steel/steel
material: St 52-3

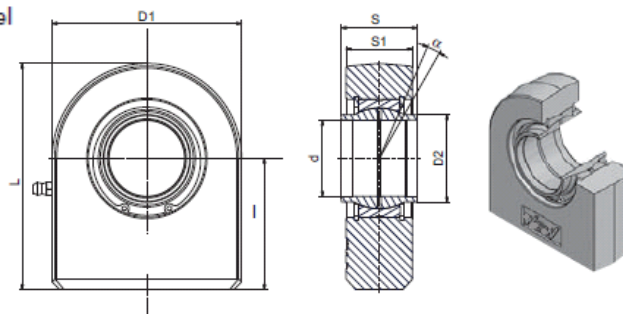

Serie/Series WS-CE-N (GN-LO)

Bezeichnung/Designation	Abmessung/Dimensions mm						
	d	S	D ₂	L	D ₁	S ₁	L
ohne Abdichtung/ without seals							
WS20CE-N	20 +0,021	20 -0,021	25	38	50	19	63
WS25CE-N	25 +0,021	25 -0,021	30,5	45	55	23	72,5
WS32CE-N	32 +0,025	32 -0,025	38	65	70	27	100
WS40CE-N	40 +0,025	40 -0,025	46	69	100	35	119
WS50CE-N	50 +0,025	50 -0,025	57	88	123	40	149,5
WS63CE-N	63 +0,030	63 -0,030	71,5	107	145	50	179,5
WS70CE-N	70 +0,030	70 -0,030	79	115	164	55	197
WS80CE-N	80 +0,030	80 -0,030	91	141	180	60	231
WS90CE-N	90 +0,035	90 -0,035	99	150	226	65	263
WS100CE-N	100 +0,035	100 -0,035	113	170	250	70	295
WS110CE-N	110 +0,035	110 -0,035	124	185	295	80	332,5

M. Wilhelmsen A/S

Århus

Herlev

Vejle

86 150 111

44 52 13 52

75 820 288

Hydraulik-Gelenkköpfe

wartungspflichtig
Gleitpaarung: Stahl/Stahl
Material: St 52-3

Hydraulic rod ends

requiring maintenance
sliding surface: steel/steel
material: St 52-3

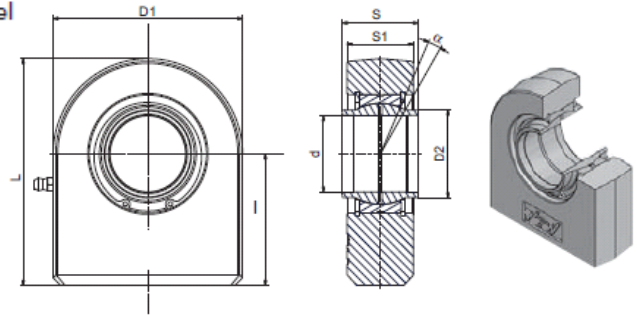

Kippwinkel/ tilting angle $\alpha^\circ \approx$	Tragzahlen/ Basic load ratings [kN]		Radiale Lagerluft/ Radial internal clearance	Gewicht/ Weight \approx kg	d
	Dyn./Dynamic	Stat./Static	CN		
4	30	74	0,030 - 0,082	0,340	20
4	48	95	0,037 - 0,100	0,510	25
4	62,5	168	0,037 - 0,100	1,08	32
4	100	268	0,043 - 0,120	2,38	40
4	156	362	0,043 - 0,120	4,32	50
4	248	570	0,055 - 0,142	7,51	63
4	315	800	0,055 - 0,142	10,31	70
4	400	874	0,055 - 0,142	14,58	80
4	490	1045	0,065 - 0,165	23,71	90
4	610	1330	0,065 - 0,165	31,91	100
4	655	1490	0,065 - 0,165	48,52	110

M. Wilhelmsen A/S

Århus

Herlev

Vejle

86 150 111

44 52 13 52

75 820 288

Hydraulik-Gelenkköpfe

wartungspflichtig

Gleitpaarung: Stahl/Stahl

Material: Ø 20 – 80 = C 45

> Ø 80 = Sphäroguss

Hydraulic rod ends

requiring maintenance

sliding surface: steel/steel

material: Ø 20 – 80 = C 45

> Ø 80 = cast iron

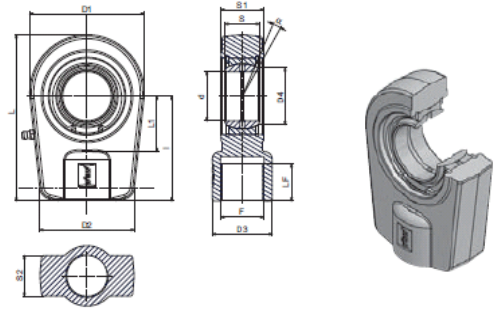

Serie/Series WAPR·N (GIHR·DO, SIRD·ES)

Bezeichnung/ Designation	Abmessung/Dimensions mm													
	d	S	I	D ₁	D ₂	S ₁	S ₂	L	L ₁	D ₃	D ₄	LF	F	
ohne Abdichtung/ without seals														
WAPR20N	20 -0,010	16 -0,12	50	56	46	19	17	80	25	25	24,1	17	M16x1,5	
WAPR25N	25 -0,010	20 -0,12	50	56	46	23	21	80	28	25	29,3	17	M16x1,5	
WAPR30N	30 -0,010	22 -0,12	60	64	50	28	26	94	30	32	34,2	23	M22x1,5	
WAPR35N	35 -0,012	25 -0,12	70	78	66	30	28	112	38	40	39,7	23	M28x1,5	
WAPR40N	40 -0,012	28 -0,12	85	94	76	35	33	135	45	49	45	30	M35x1,5	
WAPR50N	50 -0,012	35 -0,12	105	116	90	40	37	168	55	61	56	40	M45x1,5	
WAPR60N	60 -0,015	44 -0,15	130	130	120	50	46	200	65	75	66,8	53	M58x1,5	
WAPR70N	70 -0,015	49 -0,15	150	154	130	55	51	232	75	86	77,8	60	M65x1,5	
WAPR80N	80 -0,015	55 -0,15	170	176	160	60	55	265	80	105	89,4	75	M80x2	
WAPR90N	90 -0,020	60 -0,20	210	206	180	65	60	323	90	124	98,1	95	M100x2	
WAPR100N	100 -0,020	70 -0,20	235	231	200	70	65	360	105	138	109,5	103	M110x2	
WAPR110N	110 -0,020	70 -0,20	265	266	220	80	74	407,5	115	152	121,2	117	M120x3	
WAPR120N	120 -0,020	85 -0,20	310	340	257	90	84	490	140	172	135,5	127	M130x3	

M. Wilhelmsen A/S

Århus

Herlev

Vejle

86 150 111

44 52 13 52

75 820 288

Hydraulik-Gelenkköpfe

wartungspflichtig

Gleitpaarung: Stahl/Stahl

Material: Ø 20 – 80 = C 45

> Ø 80 = Sphäroguss

Hydraulic rod ends

requiring maintenance

sliding surface: steel/steel

material: Ø 20 – 80 = C 45

> Ø 80 = cast iron

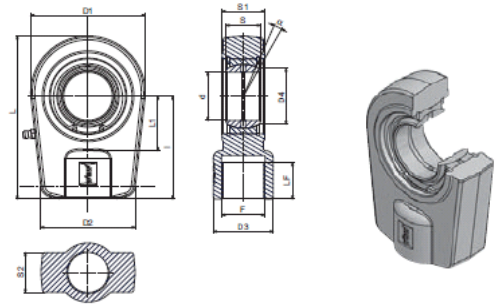

Kippwinkel/ tilting angle $\alpha^\circ \approx$	Tragzahlen/ Basic load ratings [kN]		Radiale Lagerluft/ Radial internal clearance	Gewicht/ Weight \approx kg	d
	Dyn./Dynamic	Stat./Static	CN		
9	30	81,1	0,030 - 0,082	0,430	20
7	48	72	0,037 - 0,100	0,470	25
6	62	106	0,037 - 0,100	0,760	30
6	80	153	0,037 - 0,100	1,25	35
7	100	250	0,043 - 0,120	2,14	40
6	156	365	0,043 - 0,120	3,74	50
6	245	400	0,043 - 0,120	6,34	60
6	315	540	0,055 - 0,142	9,52	70
6	400	670	0,055 - 0,142	14,07	80
5	490	980	0,055 - 0,142	22,14	90
7	610	1120	0,065 - 0,165	30,34	100
6	655	1700	0,065 - 0,165	44,50	110
6	950	2900	0,065 - 0,165	74,41	120

M. Wilhelmsen A/S

Århus

Herlev

Vejle

86 150 111

44 52 13 52

75 820 288

Hydraulik-Gelenkköpfe

klemmbar
 wartungspflichtig
 Gleitpaarung: Stahl/Stahl
 Material: Ø 20 – 80 = C 45
 > Ø 80 = Sphäroguss

Hydraulic rod ends

for clamping
 requiring maintenance
 sliding surface: steel/steel
 material: Ø 20 – 80 = C 45
 > Ø 80 = cast iron

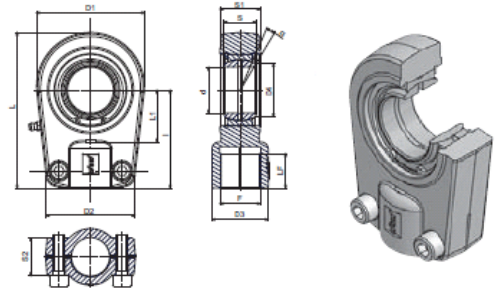

Serie/Series WAPR·U (GIHRK·DO, SIR·ES)

Bezeichnung/ Designation	Abmessung/Dimensions mm												
	d	S	I	D ₁	D ₂	S ₁	S ₂	L	L ₁	D ₃	D ₄	LF	F
ohne Abdichtung/ without seals													
WAPR20U	20 -0,010	16 -0,12	50	56	46	19	17	80	25	25	24,1	17	M16x1,5
WAPR25U	25 -0,010	20 -0,12	50	56	46	23	21	80	28	25	29,3	17	M16x1,5
WAPR30U	30 -0,010	22 -0,12	60	64	50	28	26	94	30	32	34,2	23	M22x1,5
WAPR35U	35 -0,012	25 -0,12	70	78	66	30	28	112	38	40	39,7	23	M28x1,5
WAPR40U	40 -0,012	28 -0,12	85	94	76	35	33	135	45	49	45	30	M35x1,5
WAPR50U	50 -0,012	35 -0,12	105	116	90	40	37	168	55	61	56	40	M45x1,5
WAPR60U	60 -0,015	44 -0,15	130	130	120	50	46	200	65	75	66,8	53	M58x1,5
WAPR70U	70 -0,015	49 -0,15	150	154	130	55	51	232	75	86	77,8	60	M65x1,5
WAPR80U	80 -0,015	55 -0,15	170	176	160	60	55	265	80	105	89,4	75	M80x2
WAPR90U	90 -0,020	60 -0,20	210	206	180	65	60	323	90	124	98,1	95	M100x2
WAPR100U	100 -0,020	70 -0,20	235	231	200	70	65	360	105	138	109,5	103	M110x2
WAPR110U	110 -0,020	70 -0,20	265	266	220	80	74	407,5	115	152	121,2	117	M120x3
WAPR120U	120 -0,020	85 -0,20	310	340	257	90	84	490	140	172	135,5	127	M130x3

Hydraulik-Gelenkköpfe

klemmbar

wartungspflichtig

Gleitpaarung: Stahl/Stahl

Material: Ø 20 – 80 = C 45

> Ø 80 = Sphäroguss

Hydraulic rod ends

for clamping

requiring maintenance

sliding surface: steel/steel

material: Ø 20 – 80 = C 45

> Ø 80 = cast iron

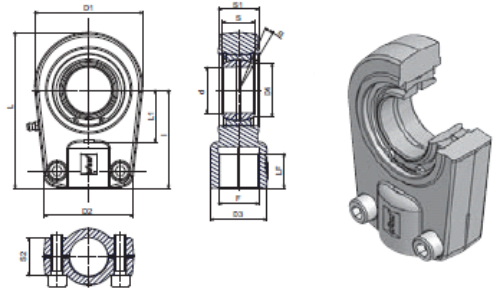

Kippwinkel/ tilting angle $\alpha^\circ \approx$	Tragzahlen/ Basic load ratings [kN]		Radiale Lagerluft/ Radial internal clearance	Schraube/Screw DIN EN ISO 4762-10.9	Anzugsmoment der Schrauben/ tightening torque [Nm]	Gewicht/ Weight ≈ kg	d
	Dyn./ Dynamic	Stat./ Static	CN				
9	30	81,1	0,030 - 0,082	M8x20	30	0,440	20
7	48	72	0,037 - 0,100	M8x20	30	0,450	25
6	62	106	0,037 - 0,100	M8x25	30	0,750	30
6	80	153	0,037 - 0,100	M10x30	54	1,22	35
7	100	250	0,043 - 0,120	M10x35	59	2,09	40
6	156	365	0,043 - 0,120	M12x40	100	3,66	50
6	245	400	0,043 - 0,120	M16x45	250	6,17	60
6	315	540	0,055 - 0,142	M16x50	250	9,32	70
6	400	670	0,055 - 0,142	M20x55	490	13,75	80
5	490	980	0,055 - 0,142	M20x60	490	21,74	90
7	610	1120	0,065 - 0,165	M24x65	840	29,54	100
6	655	1700	0,065 - 0,165	M24x80	840	43,37	110
6	950	2900	0,065 - 0,165	M24x85	840	73,48	120

M. Wilhelmsen A/S

Århus

Herlev

Vejle

86 150 111

44 52 13 52

75 820 288

Hydraulik-Gelenkköpfe

klemmbar, DIN 24338, ISO 6982
 wartungspflichtig
 Gleitpaarung: Stahl/Stahl
 Material: < Ø 80 = C 45
 > Ø 80 = Sphäroguss

Hydraulic rod ends

for clamping, DIN 24338, ISO 6982
 requiring maintenance
 sliding surface: steel/steel
 material: < Ø 80 = C 45
 > Ø 80 = cast iron

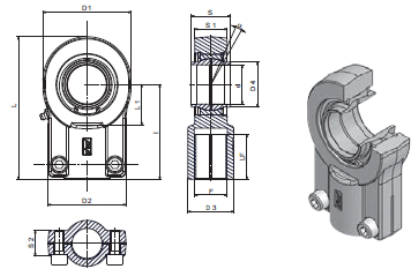

Serie/Series WAPR-CE (GIHNRK-LO, SIQG-ES)

Bezeichnung/ Designation	Abmessung/Dimensions mm												
	d	S	I	D ₁	D ₂	S ₁	S ₂	L	L ₁	D ₃	D ₄	LF	F
ohne Abdichtung/ without seals													
WAPR12CE*	12 +0,018	12 -0,18	38	32	32	11	15	54	14	16	15,5	17	M12x1,25
WAPR16CE	16 +0,018	16 -0,18	44	40	40	14	15	64	18	21	20	19	M14x1,5
WAPR20CE	20 +0,021	20 -0,21	52	47	47	17	19	77	22	25	25	23	M16x1,5
WAPR25CE	25 +0,021	25 -0,21	65	58	54	22	19	96	27	30	30,5	29	M20x1,5
WAPR32CE	32 +0,025	32 -0,25	80	71	66	28	22	118,5	32	38	37	37	M27x2
WAPR40CE	40 +0,025	40 -0,25	97	90	80	33	26	146	41	47	46	46	M33x2
WAPR50CE	50 +0,025	50 -0,25	120	109	96	40	32	179,5	50	58	57	57	M42x2
WAPR63CE	63 +0,030	63 -0,30	140	136	114	53	38	211	62	70	71,5	64	M48x2
WAPR70CE**	70 +0,030	70 -0,30	160	155	135	57	42	245	70	80	78	76	M56x2
WAPR80CE	80 +0,030	80 -0,30	180	170	148	67	48	270	78	90	91	86	M64x3
WAPR90CE**	90 +0,035	90 -0,35	195	185	160	72	52	296	85	100	99	91	M72x3
WAPR100CE	100 +0,035	100 -0,35	210	211	178	85	62	322	98	110	113	96	M80x3
WAPR110CE**	110 +0,035	110 -0,35	235	235	190	88	62	364	105	125	124	106	M90x3
WAPR125CE	125 +0,040	125 -0,40	260	265	200	103	72	405	120	135	138	113	M100x3
WAPR160CE	160 +0,040	160 -0,40	310	326	250	130	82	488	150	165	177	126	M125x4
WAPR200CE	200 +0,046	200 -0,46	390	418	320	162	102	620	195	215	221	161	M160x4
WAPR250CE	250 +0,046	250 -0,46	530	580	420	192	142	847	265	300	315	205	M200x4
WAPR320CE	320 +0,057	320 -0,57	640	700	520	260	170	1015	325	360	405	260	M250x6

Hydraulik-Gelenkköpfe

klemmbar, DIN 24338, ISO 6982

wartungspflichtig

Gleitpaarung: Stahl/Stahl

Material: < Ø 80 = C 45

> Ø 80 = Sphäroguss

Hydraulic rod ends

for clamping, DIN 24338, ISO 6982

requiring maintenance

sliding surface: steel/steel

material: < Ø 80 = C 45

> Ø 80 = cast iron

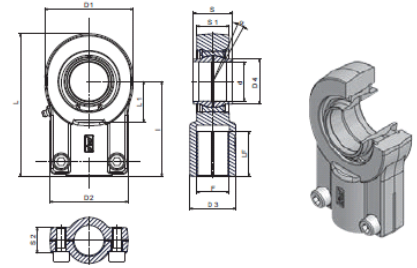

Kippwinkel/ tilting angle $\alpha^\circ \approx$	Tragzahlen/ Basic load ratings [kN]		Radiale Lagerluft/ Radial internal clearance	Schraube/Screw DIN EN ISO 4762-10.9	Anzugsmoment der Schrauben/ tightening torque [Nm]	Gewicht/ Weight \approx kg	d
	Dyn./ Dynamic	Stat./ Static	CN				
4	10,8	24,5	0,023 - 0,068	M5x16	7	0,110	12
4	17,6	36,5	0,030 - 0,082	M6x16	12	0,200	16
4	30	48	0,030 - 0,082	M8x20	30	0,350	20
4	48	78	0,037 - 0,100	M8x20	30	0,620	25
4	67	114	0,037 - 0,100	M10x25	59	1,15	32
4	100	204	0,043 - 0,120	M10x25	59	2,18	40
4	156	310	0,043 - 0,120	M12x35	100	3,96	50
4	255	430	0,055 - 0,142	M16x40	250	6,80	63
4	315	540	0,055 - 0,142	M16x40	250	9,60	70
4	400	695	0,055 - 0,142	M20x50	490	13,00	80
4	490	750	0,055 - 0,142	M20x55	490	19,10	90
4	610	1060	0,065 - 0,165	M24x60	840	25,00	100
4	655	1200	0,065 - 0,165	M24x60	840	32,00	110
4	950	1430	0,065 - 0,165	M24x70	840	46,00	125
4	1370	2200	0,065 - 0,192	M24x80	840	82,50	160
4	2120	3650	0,065 - 0,192	M30x100	1700	168,00	200
4	3550	6400	0,065 - 0,214	M36x140	2450	425,00	250
4	6100	8650	0,065 - 0,261	M36x160	2450	790,00	320

M. Wilhelmsen A/S

Århus

Herlev

Vejle

86 150 111

44 52 13 52

75 820 288

Hydraulik Gelenkköpfe

klemmbar, DIN 24555
 wartungspflichtig
 Geitpaarung: Stahl/Stahl
 Material: C 45

Hydraulic rod ends

for clamping, DIN 24555
 requiring maintenance
 sliding surface: steel/steel
 material: C 45

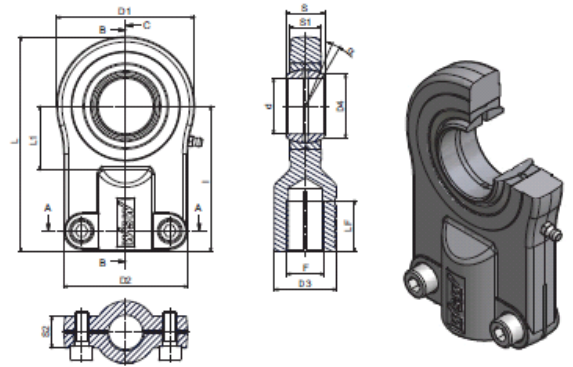

Serie/Series WAPR..S (GIHO-K..DO, SIJ..ES)

Bezeichnung/ Designation	Abmessung/Dimensions mm												
	d	S	I	D ₁	D ₂	S ₁	S ₂	L	L ₁	D ₃	D ₄	LF	F
ohne Abdichtung/ without seals													
WAPR12S *	12 -0,008	10 -0,12	42	35	35	8	13	59,5	16	17	15	15	M10x1,25
WAPR16S **	16 -0,008	14 -0,12	48	45	45	11	13	70,5	20	21	20,7	17	M12x1,25
WAPR20S **	20 -0,010	16 -0,12	58	55	55	13	17	85,5	28	25	24,1	19	M14x1,5
WAPR25S	25 -0,010	20 -0,12	68	65	62	17	17	100,5	31	30	29,3	23	M16x1,5
WAPR30S	30 -0,010	22 -0,12	85	80	77	19	19	125	35	36	34,2	29	M20x1,5
WAPR40S	40 -0,012	28 -0,12	105	100	90	23	23	155	45	45	45	37	M27x2
WAPR50S	50 -0,012	35 -0,12	130	120	105	30	30	190	58	55	56	46	M33x2
WAPR60S	60 -0,015	44 -0,15	150	160	134	38	38	230	68	68	66,8	57	M42x2
WAPR80S	80 -0,015	55 -0,15	185	205	156	47	47	287,5	92	90	89,4	64	M48x2
WAPR100S	100 -0,020	70 -0,20	240	240	190	57	55	360	116	110	109,5	90	M64x3

M. Wilhelmsen A/S

Århus

Herlev

Vejle

86 150 111

44 52 13 52

75 820 288

Hydraulik Gelenkköpfe **Hydraulic rod ends**
 klemmbar, DIN 24555 for clamping, DIN 24555
 wartungspflichtig requiring maintenance
 Geitpaarung: Stahl/Stahl sliding surface: steel/steel
 Material: C 45 material: C 45

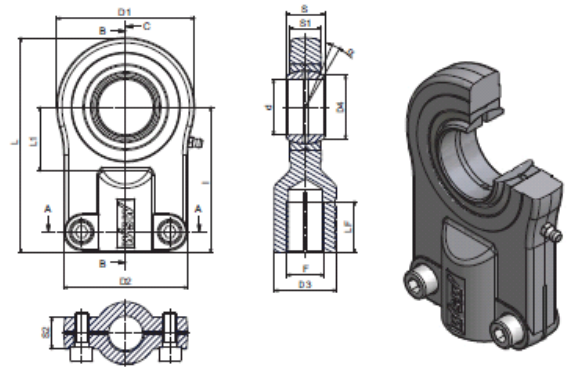

Kippwinkel/ tilting angle	Tragzahlen/ Basic load ratings [kN]		Radiale Lagerluft/ Radial internal clearance	Schraube/Screw DIN EN ISO 4762-10.9	Anzugsmoment der Schrauben/ tightening torque [Nm]	Gewicht/ Weight ≈ kg	d
	Dyn./ Dynamic	Stat./ Static	CN				
11	10,8	17	0,023 - 0,068	M6x12	12	0,120	12
10	21,1	28,5	0,040 - 0,082	M6x14	12	0,230	16
9	30	42,5	0,040 - 0,082	M8x16	30	0,410	20
7	48	67	0,050 - 0,100	M8x16	30	0,660	25
6	62	108	0,050 - 0,100	M10x20	59	1,15	30
7	100	156	0,060 - 0,120	M10x25	59	2,08	40
6	156	245	0,060 - 0,120	M12x30	100	3,82	50
6	245	380	0,060 - 0,120	M16x35	250	7,72	60
6	400	585	0,072 - 0,142	M20x45	490	15,11	80
6	610	865	0,085 - 0,165	M24x55	840	27,52	100

Hydraulik-Gelenkköpfe

schwere Ausführung
 klemmbar
 wartungspflichtig
 Gleitpaarung: Stahl/Stahl
 Material: < Ø 50 = C45
 > Ø 50 = Sphäroguss

Hydraulic rod ends

heavy duty
 for clamping
 requiring maintenance
 sliding surface: steel/steel
 material: < Ø 50 = C45
 > Ø 50 = cast iron

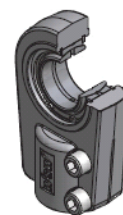
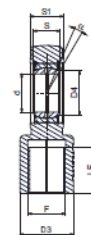
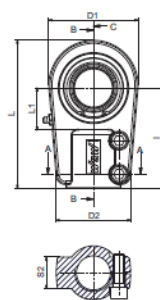

Serie/Series WGAS**

Bezeichnung/ Designation	Abmessung/Dimensions mm												
	d	S	I	D ₁	D ₂	S ₁	S ₂	L	L ₁	D ₃	D ₄	LF	F
WGAS25	25 -0,010	20 -0,12	65	56	48	23	21	95	29	28	29,3	30	M18x2
WGAS30	30 -0,010	22 -0,12	75	64	56	28	26	109	34	34	34,2	35	M24x2
WGAS35	35 -0,012	25 -0,12	90	78	66	30	28	132	40	45	39,7	40	M30x2
WGAS40	40 -0,012	28 -0,12	105	94	78	35	33	155	44	56,5	45	48	M39x3
WGAS50	50 -0,012	35 -0,12	135	116	89	40	36	198	55	70	56	66	M50x3
WGAS60	60 -0,015	44 -0,15	170	130	118	50	46	240	65	87	66,8	84	M64x3
WGAS70	70 -0,015	49 -0,15	195	154	128	55	51	277	75	110	77,8	100	M80x3
WGAS80	80 -0,015	55 -0,15	210	176	156	60	55	305	80	128	89,4	110	M90x3
WGAS90	90 -0,020	60 -0,20	250	210	168	65	60	365	90	152	98,1	130	M100x3
WGAS100	100 -0,020	70 -0,20	275	230	171	70	65	400	105	170	109,5	138	M110x4
WGAS110	110 -0,020	70 -0,20	300	264	189	80	75	442	115	180	121,2	145	M120x4
WGAS120	120 -0,020	85 -0,20	360	340	243	90	85	540	140	210	135,5	177	M150x4
WGAS140	140 -0,025	90 -0,25	420	380	248	110	105	620	185	230	154	190	M160x4
WGAS160	160 -0,025	105 -0,25	460	480	273	110	105	710	200	260	170	200	M180x4

M. Wilhelmsen A/S

Århus

Herlev

Vejle

86 150 111

44 52 13 52

75 820 288

Hydraulik-Gelenkköpfe

schwere Ausführung

klemmbar

wartungspflichtig

Gleitpaarung: Stahl/Stahl

Material: < Ø 50 = C45

> Ø 50 = Sphäroguss

Hydraulic rod ends

heavy duty

for clamping

requiring maintenance

sliding surface: steel/steel

material: < Ø 50 = C45

> Ø 50 = cast iron

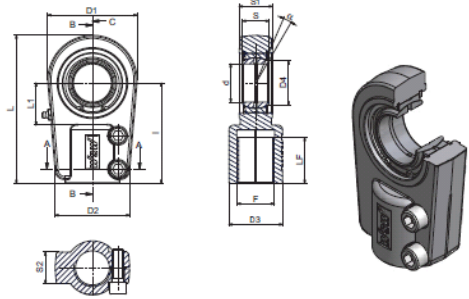

Kippwinkel/ tilting angle $\alpha^\circ \approx$	Tragzahlen/ Basic load ratings [kN]		Radiale Lagerluft/ Radial internal clearance	Schraube/Screw DIN EN ISO 4762-10.9	Anzugsmoment der Schrauben/ tightening torque [Nm]	Gewicht/ Weight \approx kg	d
	Dyn./ Dynamic	Stat./ Static	CN				
7	48	82	0,037 - 0,100	M8x20	30	0,580	25
6	62	122	0,037 - 0,100	M8x25	30	0,900	30
6	80	177	0,037 - 0,100	M10x30	59	1,51	35
7	100	287	0,043 - 0,120	M12x35	100	2,51	40
6	156	422	0,043 - 0,120	M12x35	100	4,47	50
6	245	522	0,043 - 0,120	M16x45	250	7,46	60
6	315	707	0,055 - 0,142	M16x50	250	11,30	70
6	400	870	0,055 - 0,142	M20x55	490	15,46	80
5	490	1284	0,055 - 0,142	M20x60	490	27,41	90
7	610	1460	0,085 - 0,165	M20x60	490	34,26	100
6	655	2024	0,085 - 0,165	M24x75	840	47,07	110
6	950	2970	0,085 - 0,165	M24x85	840	85,56	120
7	1070	3350	0,085 - 0,165	M30x100	1700	123,50	140
8	1370	4302	0,085 - 0,165	M30x100	1700	186,70	160

M. Wilhelmsen A/S

Århus

Herlev

Vejle

86 150 111

44 52 13 52

75 820 288