

# **M** **WILHELMSEN** A/s



## **STAINLESS STEEL BEARING**

**Århus**

**86 150 111**

**Herlev**

**44 52 13 52**

**Vejle**

**75 820 288**

# TABLE OF CONTENTS

Technical information.....	4
Stainless steel SUCP.....	6
Stainless steel SUCF.....	8
Stainless steel SUCPA.....	10
Stainless steel SUCFL.....	12
Stainless steel SUCT.....	14
Stainless steel SUCFC.....	16
Stainless steel SUCFB.....	18
Stainless steel SUCFA.....	20
Thermoplastic SUCPPL.....	22
Thermoplastic SUCFPL.....	24
Thermoplastic SUCNFL.....	26
Thermoplastic SUCFBL.....	28
Thermoplastic SUCHPL.....	30
Thermoplastic SUCTPL.....	32
Thermoplastic SUCTBL.....	34
Thermoplastic Covers/dæksler .....	36

# TABLE OF CONTENTS

Stainless steel bearing insert SUC200.....	37
Stainless steel bearing insert SSA200.....	38
Stainless steel bearing insert SSB200.....	39
Stainless steel bearing insert SS6000.....	40
Stainless steel radial bearing SS6200.....	41
Stainless steel radial bearing SS6300.....	42
Stainless steel radial bearing SS6800(SS61800).....	43
Stainless steel radial bearing SS6900(SS61900).....	44
Stainless steel miniature bearing insert MUFL000.....	45
Stainless steel miniature bearing insert MUP000.....	46
Stainless steel miniature bearing insert SU000 MU000.....	47
Kataloger på vores hjemmeside - <a href="http://dkc-as.dk/">http://dkc-as.dk/</a> .....	48-51

# TECHNICAL INFORMATION

## Rolling bearing structure and feature

Rolling bearing normally comprise bearing rings (inner ring and outer ring), rolling element and cage. Rolling elements are arranged between inner and outer rings, and cage to make sure the rolling elements in the correct relative position. This is arranged so that they do not contact each other. With this structure, a rolling motion is operational possible. The load of bearing is supported by the contact surface or point of rolling elements and rings.

## Stainless steel bearing materials

**EDB – bearings in stainless steel materials are**

Inner and Outer rings, balls:

A martensitic type, S440C, is highly resistant to perform under corrosive application.

this is a straight chromium steel, and also provides maximum hardness and dimensional stability.

Retainers and metal shields: Stainless steel S304

Rubber seals: Nitril rubber (standard) any others available upon request

All SS bearings comes **with food grease Mobil FM222 type.**

No standard: Upon request, Nylon cage retainer or ceramic balls type can be catered upon request.

## Bearing tolerance

Bearing tolerance include both dimension tolerance and rotate tolerance. This bearing tolerance adapt: P0, P6, P5, P4 as well as ISO standard. They are comparing as follows:

### Comparison Of Tolerance:

Standard code	Tolerance			
GB	P0	P6	P5	P4
ISO	NORMAL CLASS	CLASS6	CLASS5	CLASS4
SKF	P0	P6	P5	P4
DIN	P0	P6	P5	P4
JIS	P0	P6	P5	P4
ANSI	ABEC-1	ABEC-3	ABEC-5	ABEC-7

# TECHNICAL INFORMATION

## STAINLESS STEEL BEARING UNITS



# SUCP 200 SERIES STAINLESS STEEL



## TECHNICAL DATA

Our 100% stainless steel units are manufactured from a select grade of stainless steel which has been carefully chosen to give you what you've asked for: optimal corrosion resistance. Bearing life is excellent because it is not limited to the life of the coating and/or nickel plating.

Ring & Balls	S420C
Slinger and Retainer	S420C
Seal	Nitril rubber (NBR)
Housing	S420C
Tolerance	P0 (ABEC1)
Bearing-grease	Mobil FM222 food grease (FDA)

## OPERATING TEMPERATURE RANGE

-20~+120c

Scratchers and mars have absolutely no effect on the bearing's ability to resist rust and corrosion.

Excellent for use in food processing, beverage and other high-corrosive applications, these bearings are 100% stainless throughout: housing, balls, inner and outer races, cages, slingers and set screws.

## Specifications and Approvals: Mobil FM222

Mobilgrease FM meets or exceeds the requirements of:	FM 101	FM 222
FDA 21 CFR 178.3570	X	X
DIN 51825 (2006:06)	KPF1K -20	KPF2K -20
Mobilgrease FM has the following builder approvals:	FM 101	FM 222
MAG IAS, LLC	P-72	P-64
Kosher/Parve	X	X
Halal	X	X
Mobilgrease FM is Registered to the requirement of:	FM 101	FM 222
NSF H1	X	X
NSF Registration Number	141881	136449

# SUCP 200 SERIES STAINLESS STEEL

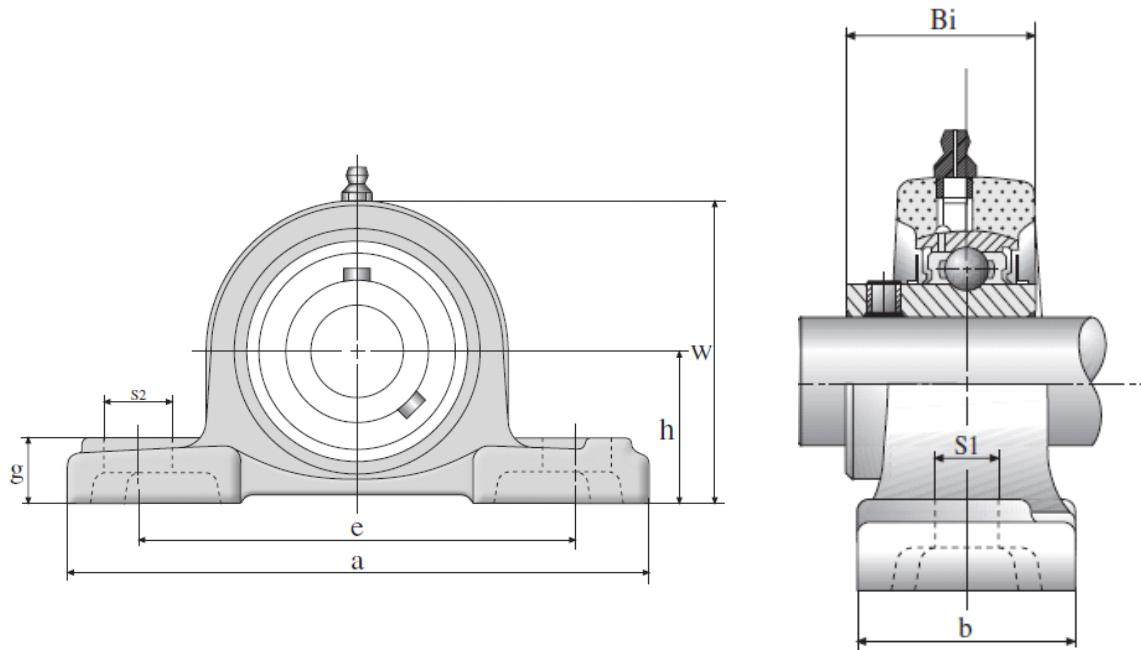

UNIT NUMBER	Bore Dia (mm) d	h	a	e	b	S1	S2	g	w	s	kg	Bearing NO.	Housing NO.
SUCP201	12	33,3	127	96	36	13	19	13	60	12,7	0,75	SUC201	SP203
SUCP202	15	33,3	127	96	36	13	19	13	60	12,7	0,75	SUC202	SP203
SUCP203	17	33,3	127	96	36	13	19	13	60	12,7	0,75	SUC203	SP203
SUCP204	20	33,3	127	96	38	13	19	14	65	12,7	0,73	SUC204	SP204
SUCP205	25	36,5	140	105	38	13	19	15	71	14,3	0,91	SUC205	SP205
SUCP206	30	42,9	165	121	48	17	21	17	83	15,9	1,32	SUC206	SP206
SUCP207	35	47,6	167	127	48	17	21	18	93	17,5	1,72	SUC207	SP207
SUCP208	40	49,2	184	136,5	54	17	23	18	98	19,0	2,14	SUC208	SP208
SUCP209	45	54,0	190	146	54	17	23	20	106	19,0	2,45	SUC209	SP209
SUCP210	50	57,2	206	159	60	20	25	21	114	19,0	3,10	SUC210	SP210
SUCP211	55	63,5	219	171	60	20	25	23	126	22,2	3,85	SUC211	SP211
SUCP212	60	69,8	241	184	70	20	25	25	138	25,4	5,10	SUC212	SP212
SUCP213	65	76,2	264	203	70	25	30	27	151	25,4	6,26	SUC213	SP213
SUCP214	70	79,4	266	210	72	25	30	27	157	30,2	6,90	SUC214	SP214
SUCP215	75	82,6	275	217	74	25	30	28	163	33,3	7,62	SUC215	SP215
SUCP216	80	88,9	292	232	78	25	30	30	175	33,3	9,03	SUC216	SP216
SUCP217	85	95,2	310	247	83	25	30	32	187	34,1	11,28	SUC217	SP217
SUCP218	90	101,6	327	262	88	27	36	33	200	39,7	13,45	SUC218	SP218

# SUCF 200 SERIES STAINLESS STEEL



## TECHNICAL DATA

Our 100% stainless steel units are manufactured from a select grade of stainless steel which has been carefully chosen to give you what you've asked for: optimal corrosion resistance. Bearing life is excellent because it is not limited to the life of the coating and/or nickel plating.

Ring & Balls	S420C
Slinger and Retainer	S420C
Seal	Nitril rubber (NBR)
Housing	S420C
Tolerance	P0 (ABEC1)
Bearing-grease	Mobil FM222 food grease (FDA)

## OPERATING TEMPERATURE RANGE

-20~+120c

Scratchers and mars have absolutely no effect on the bearing's ability to resist rust and corrosion.

Excellent for use in food processing, beverage and other high-corrosive applications, these bearings are 100% stainless throughout: housing, balls, inner and outer races, cages, slingers and set screws.

## Specifications and Approvals: Mobil FM222

Mobilgrease FM meets or exceeds the requirements of:	FM 101	FM 222
FDA 21 CFR 178.3570	X	X
DIN 51825 (2006:06)	KPF1K -20	KPF2K -20
Mobilgrease FM has the following builder approvals:	FM 101	FM 222
MAG IAS, LLC	P-72	P-64
Kosher/Parve	X	X
Halal	X	X
Mobilgrease FM is Registered to the requirement of:	FM 101	FM 222
NSF H1	X	X
NSF Registration Number	141881	136449



# SUCF 200 SERIES STAINLESS STEEL

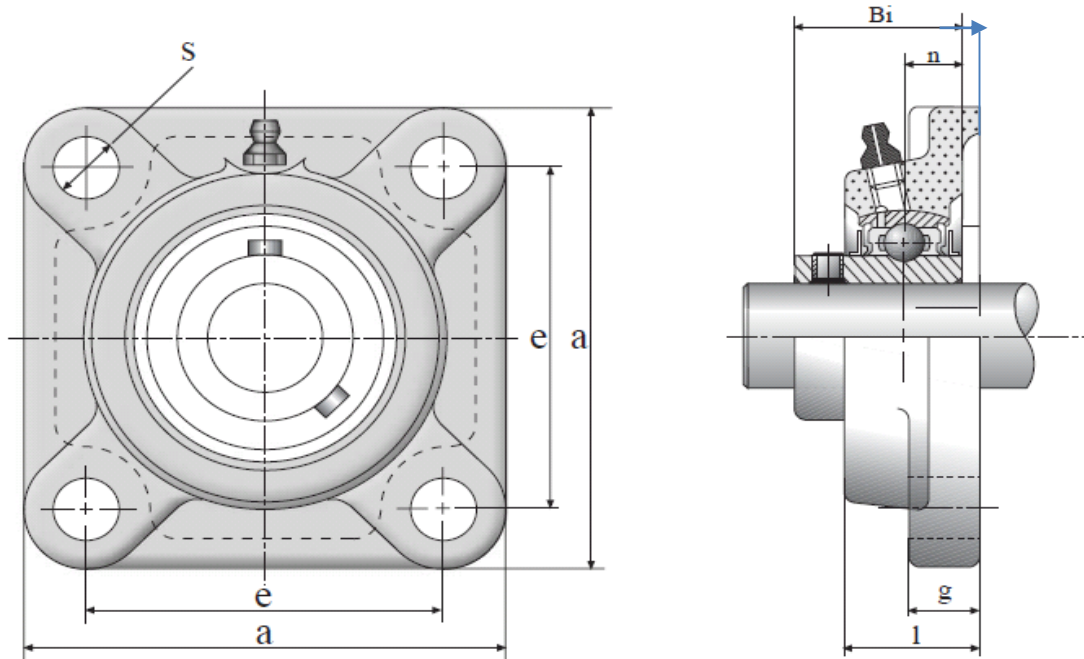

UNIT NUMBER	Bore Dia (mm) d	a	e	i	g	L	Bi	S	Bearing NO.	Housing NO.
SUCF201	12	86	64	15	11	25,5	33,3	12	SUC201	SF203
SUCF202	15	86	64	15	11	25,5	33,3	12	SUC202	SF203
SUCF203	17	86	64	15	11	25,5	33,3	12	SUC203	SF203
SUCF204	20	86	64	15	12	25,5	33,3	12	SUC204	SF204
SUCF205	25	95	70	16	14	27	35,8	12	SUC205	SF205
SUCF206	30	108	83	18	14,3	31	40,2	12	SUC206	SF206
SUCF207	35	117	92	19	15,5	34	44,4	14	SUC207	SF207
SUCF208	40	130	102	21	15,5	36	51,2	16	SUC208	SF208
SUCF209	45	137	105	22	17,5	38	52,2	16	SUC209	SF209
SUCF210	50	143	111	22	17,5	40	54,6	16	SUC210	SF210
SUCF211	55	162	130	25	19,5	43	58,4	19	SUC211	SF211
SUCF212	60	175	143	29	19,5	48	68,7	19	SUC212	SF212
SUCF213	65	187	149	30	23	50	69,7	19	SUC213	SF213
SUCF214	70	193	152	31	23	54	75,4	19	SUC214	SF214
SUCF215	75	200	159	34	23	56	78,5	19	SUC215	SF215
SUCF216	80	208	165	34	24	58	83,3	23	SUC216	SF216
SUCF217	85	220	175	36	25	63	87,6	23	SUC217	SF217
SUCF218	90	235	187	40	26	68	96,3	23	SUC218	SF218

# SUCPA 200 SERIES STAINLESS STEEL



## TECHNICAL DATA

Our 100% stainless steel units are manufactured from a select grade of stainless steel which has been carefully chosen to give you what you've asked for: optimal corrosion resistance. Bearing life is excellent because it is not limited to the life of the coating and/or nickel plating.

Ring & Balls	S420C
Slinger and Retainer	S420C
Seal	Nitril rubber (NBR)
Housing	S420C
Tolerance	P0 (ABEC1)
Bearing-grease	Mobil FM222 food grease (FDA)

## OPERATING TEMPERATURE RANGE

-20~+120c

Scratchers and mars have absolutely no effect on the bearing's ability to resist rust and corrosion.

Excellent for use in food processing, beverage and other high-corrosive applications, these bearings are 100% stainless throughout: housing, balls, inner and outer races, cages, slingers and set screws.

## Specifications and Approvals: Mobil FM222

Mobilgrease FM meets or exceeds the requirements of:	FM 101	FM 222
FDA 21 CFR 178.3570	X	X
DIN 51825 (2006:06)	KPF1K -20	KPF2K -20
Mobilgrease FM has the following builder approvals:	FM 101	FM 222
MAG IAS, LLC	P-72	P-64
Kosher/Parve	X	X
Halal	X	X
Mobilgrease FM is Registered to the requirement of:	FM 101	FM 222
NSF H1	X	X
NSF Registration Number	141881	136449

## SUCPA 200 SERIES STAINLESS STEEL

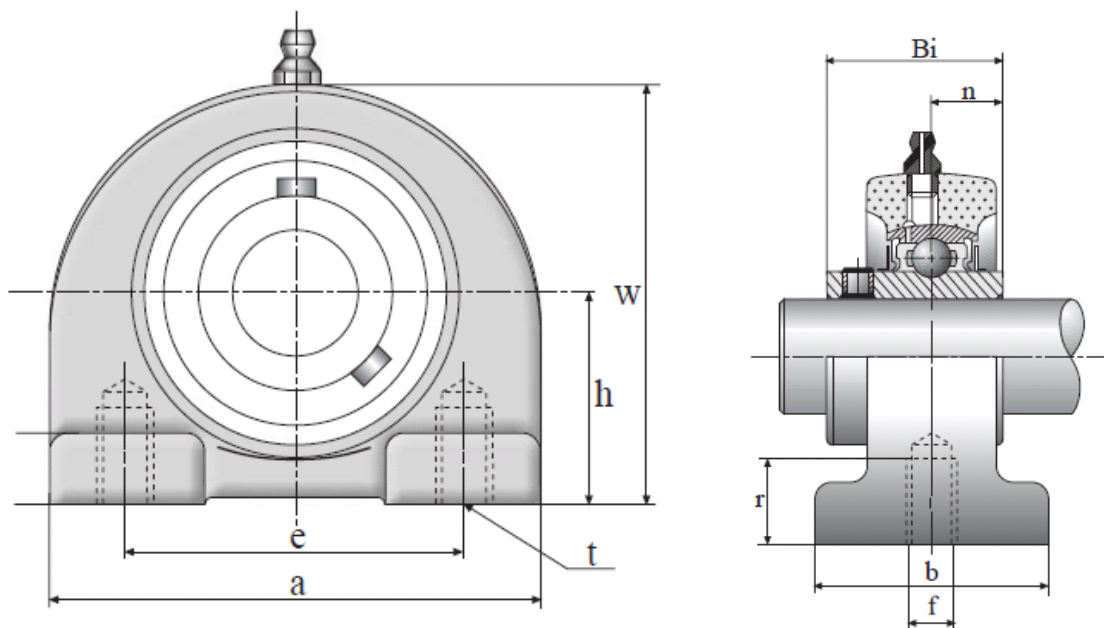

UNIT NUMBER	Bore Dia (mm) d	h	a	e	b	Bi	g	W	f	Bearing NO.	Housing NO.
SUCPA201	12	30,2	76	52	40	31	11	62	M10	SUC201	SPA201
SUCPA202	15	30,2	76	52	40	31	11	62	M10	SUC202	SPA202
SUCPA203	17	30,2	76	52	40	31	11	62	M10	SUC203	SPA203
SUCPA204	20	30,2	76	52	40	31	11	62	M10	SUC204	SPA204
SUCPA205	25	36,5	84	56	45	34,1	12	72	M10	SUC205	SPA205
SUCPA206	30	42,9	94	66	50	38,1	12	84	M14	SUC206	SPA206
SUCPA207	35	47,6	110	80	55	42,9	13	95	M14	SUC207	SPA207
SUCPA208	40	49,2	116	84	58	49,2	13	100	M14	SUC208	SPA208
SUCPA209	45	54,2	120	90	60	49,2	13	108	M14	SUC209	SPA209
SUCPA210	50	57,2	130	90	64	51,6	14	116	M16	SUC210	SPA210
SUCPA211	55	63,5	140	104	66	55,6	14	125	M16	SUC211	SPA211
SUCPA212	60	69,9	150	114	68	65,1	15	138	M16	SUC212	SPA212
SUCPA213	65	76,2	160	124	70	65,1	15	150	M16	SUC213	SPA213

# SUCFL 200 SERIES STAINLESS STEEL



## TECHNICAL DATA

Our 100% stainless steel units are manufactured from a select grade of stainless steel which has been carefully chosen to give you what you've asked for: optimal corrosion resistance. Bearing life is excellent because it is not limited to the life of the coating and/or nickel plating.

Ring & Balls	S420C
Slinger and Retainer	S420C
Seal	Nitril rubber (NBR)
Housing	S420C
Tolerance	P0 (ABEC1)
Bearing-grease	Mobil FM222 food grease (FDA)

## OPERATING TEMPERATURE RANGE

-20~+120c

Scratchers and mars have absolutely no effect on the bearing's ability to resist rust and corrosion.

Excellent for use in food processing, beverage and other high-corrosive applications, these bearings are 100% stainless throughout: housing, balls, inner and outer races, cages, slingers and set screws.

## Specifications and Approvals: Mobil FM222

Mobilgrease FM meets or exceeds the requirements of:	FM 101	FM 222
FDA 21 CFR 178.3570	X	X
DIN 51825 (2006:06)	KPF1K -20	KPF2K -20
Mobilgrease FM has the following builder approvals:	FM 101	FM 222
MAG IAS, LLC	P-72	P-64
Kosher/Parve	X	X
Halal	X	X
Mobilgrease FM is Registered to the requirement of:	FM 101	FM 222
NSF H1	X	X
NSF Registration Number	141881	136449

# SUCFL 200 SERIES

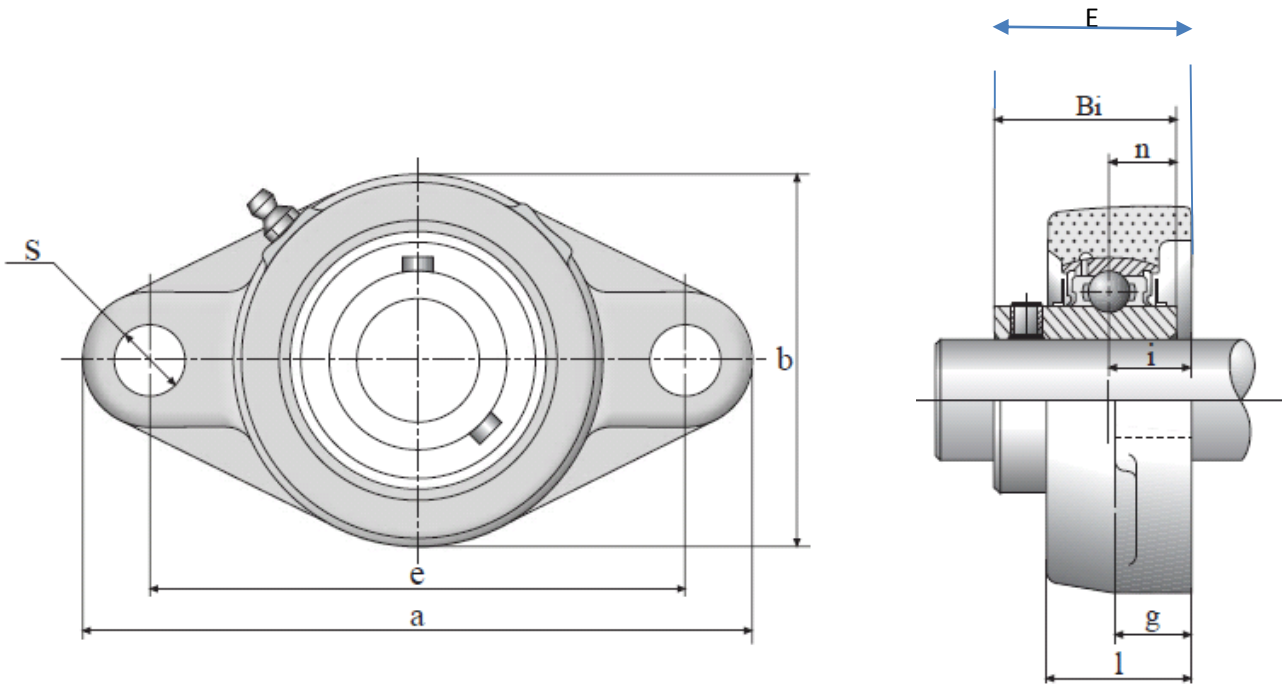

UNIT NUMBER	Bore Dia (mm) d	a	e	i	b	g	L	N	E	s	Kg	Bearing NO.	Housing NO.
SUCFL201	12	99	76,2	15	57	11	25,5	11,5	33,3	12,7	0,56	SUC201	SFL203
SUCFL202	15	99	76,2	15	57	11	25,5	11,5	33,3	12,7	0,56	SUC202	SFL203
SUCFL203	17	99	76,2	15	57	11	25,5	11,5	33,3	12,7	0,56	SUC203	SFL203
SUCFL204	20	113	90	15	60	11	25,5	12	33,3	12,7	0,52	SUC204	SFL204
SUCFL205	25	130	99	16	68	13	27	16	35,8	14,3	0,64	SUC205	SFL205
SUCFL206	30	148	117	18	80	13	31	16	40,2	15,9	0,93	SUC206	SFL206
SUCFL207	35	161	130	19	90	15	34	16	44,4	17,5	1,20	SUC207	SFL207
SUCFL208	40	175	144	21	100	15	36	16	51,2	19,0	1,59	SUC208	SFL208
SUCFL209	45	188	148	22	108	16	38	19	52,2	19,0	1,84	SUC209	SFL209
SUCFL210	50	197	157	22	115	16	40	19	54,6	19,0	2,15	SUC210	SFL210
SUCFL211	55	224	184	25	130	18	43	19	58,4	22,2	3,10	SUC211	SFL211
SUCFL212	60	250	202	29	140	18	48	23	68,7	25,4	3,99	SUC212	SFL212
SUCFL213	65	258	210	30	155	22	50	23	69,7	25,4	4,96	SUC213	SFL213
SUCFL214	70	265	216	31	160	22	54	23	75,4	30,2	5,60	SUC214	SFL214
SUCFL215	75	275	225	34	165	22	56	23	78,5	33,3	6,21	SUC215	SFL215
SUCFL216	80	290	233	34	180	22	58	25	83,3	33,3	7,69	SUC216	SFL216
SUCFL217	85	305	248	36	190	24	63	25	87,6	34,1	9,15	SUC217	SFL217
SUCFL218	90	320	265	40	205	24	68	25	96,3	39,7	10,95	SUC218	SFL218

# SUCT 200 SERIES STAINLESS STEEL



## TECHNICAL DATA

Our 100% stainless steel units are manufactured from a select grade of stainless steel which has been carefully chosen to give you what you've asked for: optimal corrosion resistance. Bearing life is excellent because it is not limited to the life of the coating and/or nickel plating.

Ring & Balls	S420C
Slinger and Retainer	S420C
Seal	Nitril rubber (NBR)
Housing	S420C
Tolerance	P0 (ABEC1)
Bearing-grease	Mobil FM222 food grease (FDA)

## OPERATING TEMPERATURE RANGE

-20~+120c

Scratchers and mars have absolutely no effect on the bearing's ability to resist rust and corrosion.

Excellent for use in food processing, beverage and other high-corrosive applications, these bearings are 100% stainless throughout: housing, balls, inner and outer races, cages, slingers and set screws.

## Specifications and Approvals: Mobil FM222

Mobilgrease FM meets or exceeds the requirements of:	FM 101	FM 222
FDA 21 CFR 178.3570	X	X
DIN 51825 (2006:06)	KPF1K -20	KPF2K -20
Mobilgrease FM has the following builder approvals:	FM 101	FM 222
MAG IAS, LLC	P-72	P-64
Kosher/Parve	X	X
Halal	X	X
Mobilgrease FM is Registered to the requirement of:	FM 101	FM 222
NSF H1	X	X
NSF Registration Number	141881	136449

# SUCT 200 SERIES STAINLESS STEEL

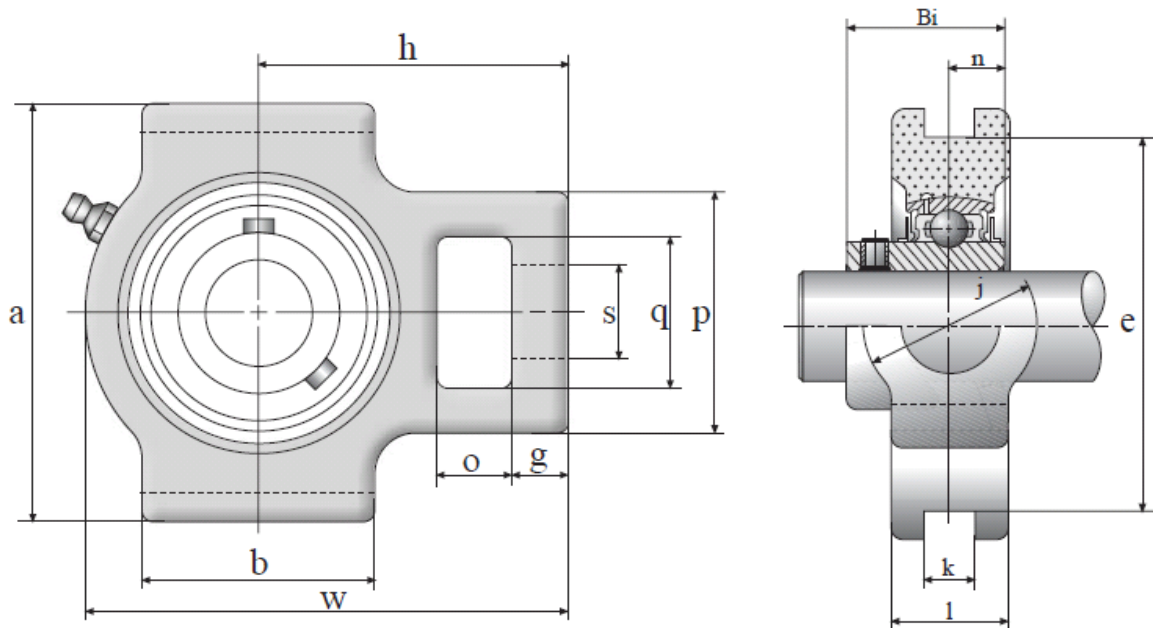

UNIT NUMBER	Bore Dia (mm) d	o	g	p	Q	S	b	e	a	w	h	k	L	Bearing No.	Housing No.
SUCT201	12	16	10	51	32	19	51	76	89	94	61	12	21	SUC201	ST201
SUCT202	15	16	10	51	32	19	51	76	89	94	61	12	21	SUC202	ST202
SUCT203	17	16	10	51	32	19	51	76	89	94	61	12	21	SUC203	ST203
SUCT204	20	16	10	51	32	19	51	76	89	94	61	12	21	SUC204	ST204
SUCT205	25	16	10	51	32	19	51	76	89	97	62	12	24	SUC205	ST205
SUCT206	30	16	10	56	37	22	57	89	102	113	70	12	28	SUC206	ST206
SUCT207	35	16	13	64	37	22	64	89	102	129	78	12	30	SUC207	ST207
SUCT208	40	19	16	83	49	29	83	102	114	144	88	16	33	SUC208	ST208
SUCT209	45	19	16	83	49	29	83	102	117	144	87	16	35	SUC209	ST209
SUCT210	50	19	16	83	49	29	86	102	117	149	90	16	37	SUC210	ST210
SUCT211	55	25	19	102	64	35	95	130	146	171	106	22	38	SUC211	ST211
SUCT212	60	32	19	102	64	35	102	130	146	194	119	22	42	SUC212	ST212
SUCT213	65	32	21	111	70	41	121	151	167	224	137	26	44	SUC213	ST213
SUCT214	70	32	21	111	70	41	121	151	167	224	137	26	46	SUC214	ST214
SUCT215	75	32	21	111	70	41	121	151	167	232	140	26	48	SUC215	ST215
SUCT216	80	32	21	111	70	41	121	165	184	235	140	26	51	SUC216	ST216
SUCT217	85	38	29	124	73	48	157	173	198	260	162	30	54	SUC217	ST217
SUCT218	90	40	30	130	80	48	140	190	215	275	170	30	55	SUC218	ST218

# SUCFC 200 SERIES STAINLESS STEEL



## TECHNICAL DATA

Our 100% stainless steel units are manufactured from a select grade of stainless steel which has been carefully chosen to give you what you've asked for: optimal corrosion resistance. Bearing life is excellent because it is not limited to the life of the coating and/or nickel plating.

Ring & Balls	S420C
Slinger and Retainer	S420C
Seal	Nitril rubber (NBR)
Housing	S420C
Tolerance	P0 (ABEC1)
Bearing-grease	Mobil FM222 food grease (FDA)

## OPERATING TEMPERATURE RANGE

-20~+120c

Scratchers and marks have absolutely no effect on the bearing's ability to resist rust and corrosion.

Excellent for use in food processing, beverage and other high-corrosive applications, these bearings are 100% stainless throughout: housing, balls, inner and outer races, cages, slingers and set screws.

## Specifications and Approvals: Mobil FM222

Mobilgrease FM meets or exceeds the requirements of:	FM 101	FM 222
FDA 21 CFR 178.3570	X	X
DIN 51825 (2006:06)	KPF1K -20	KPF2K -20
Mobilgrease FM has the following builder approvals:	FM 101	FM 222
MAG IAS, LLC	P-72	P-64
Kosher/Parve	X	X
Halal	X	X
Mobilgrease FM is Registered to the requirement of:	FM 101	FM 222
NSF H1	X	X
NSF Registration Number	141881	136449



## SUCFC 200 SERIES STAINLESS STEEL

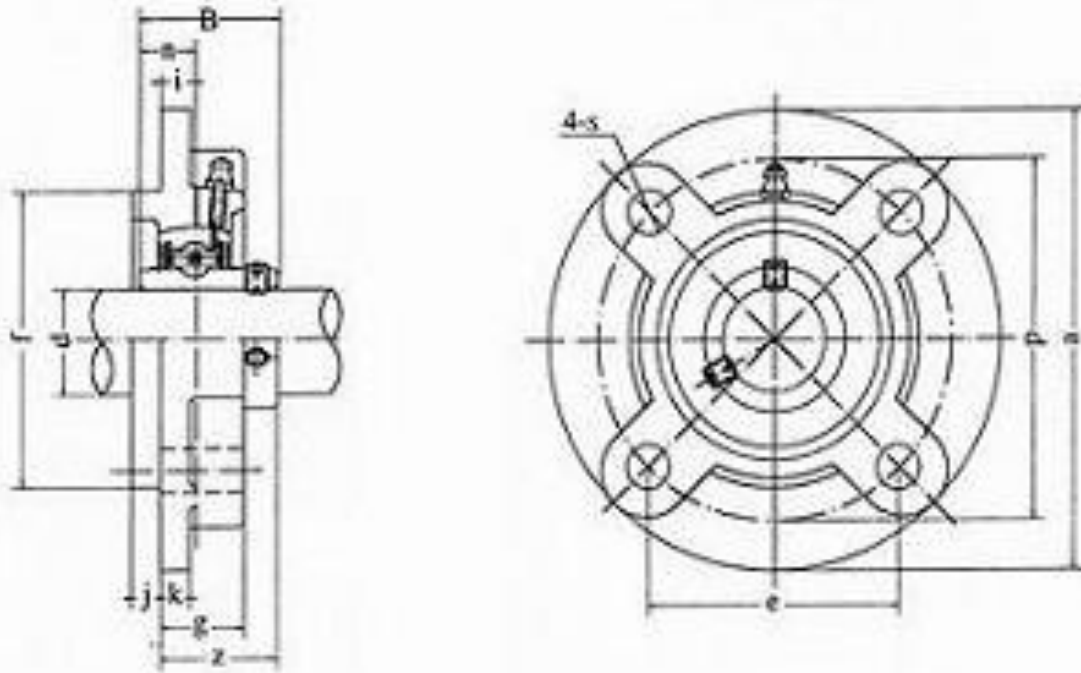

UNIT NUMBER	Bore Dia (mm) d	a	p	e	s	z+j	f	kg	Bearing No.	Housing No.
SUCFC201	12	100	78	55,1	12	33,3	62	1,00	SUC201	SFC201
SUCFC202	15	100	78	55,1	12	33,3	62	1,00	SUC202	SFC202
SUCFC203	17	100	78	55,1	12	33,3	62	1,00	SUC203	SFC203
SUCFC204	20	100	78	55,1	12	33,6	62	0,96	SUC204	SFC204
SUCFC205	25	115	90	63,6	12	35,80	70	1,24	SUC205	SFC205
SUCFC206	30	125	100	70,7	12	40,20	80	1,66	SUC206	SFC206
SUCFC207	35	135	110	77,8	14	44,40	90	2,11	SUC207	SFC207
SUCFC208	40	145	120	84,8	14	51,20	100	2,48	SUC208	SFC208
SUCFC209	45	160	132	93,3	16	52,20	105	3,35	SUC209	SFC209
SUCFC210	50	165	138	97,6	16	54,60	110	3,58	SUC210	SFC210
SUCFC211	55	185	150	106,1	19	58,40	125	5,07	SUC211	SFC211
SUCFC212	60	195	160	113,1	19	68,70	135	5,97	SUC212	SFC212
SUCFC213	65	205	170	120,1	19	69,70	145	6,50	SUC213	SFC213
SUCFC214	70	215	177	125,1	19	75,40	150	7,86	SUC214	SFC214
SUCFC215	75	220	184	130,1	19	78,50	160	8,59	SUC215	SFC215
SUCFC216	80	240	200	141,4	23	83,3	170	10,52	SUC216	SFC216
SUCFC217	85	250	208	147,1	23	87,60	180	12,46	SUC217	SFC217
SUCFC218	90	265	220	155,5	23	96,30	190	14,83	SUC218	SFC218

# SUCFB 200 SERIES STAINLESS STEEL



## TECHNICAL DATA

Our 100% stainless steel units are manufactured from a select grade of stainless steel which has been carefully chosen to give you what you've asked for: optimal corrosion resistance. Bearing life is excellent because it is not limited to the life of the coating and/or nickel plating.

Ring & Balls	S420C
Slinger and Retainer	S420C
Seal	Nitril rubber (NBR)
Housing	S420C
Tolerance	P0 (ABEC1)
Bearing-grease	Mobil FM222 food grease (FDA)

## OPERATING TEMPERATURE RANGE

-20~+120c

Scratchers and mars have absolutely no effect on the bearing's ability to resist rust and corrosion.

Excellent for use in food processing, beverage and other high-corrosive applications, these bearings are 100% stainless throughout: housing, balls, inner and outer races, cages, slingers and set screws.

## Specifications and Approvals: Mobil FM222

Mobilgrease FM meets or exceeds the requirements of:	FM 101	FM 222
FDA 21 CFR 178.3570	X	X
DIN 51825 (2006:06)	KPF1K -20	KPF2K -20
Mobilgrease FM has the following builder approvals:	FM 101	FM 222
MAG IAS, LLC	P-72	P-64
Kosher/Parve	X	X
Halal	X	X
Mobilgrease FM is Registered to the requirement of:	FM 101	FM 222
NSF H1	X	X
NSF Registration Number	141881	136449

# SUCFB 200 SERIES STAINLESS STEEL

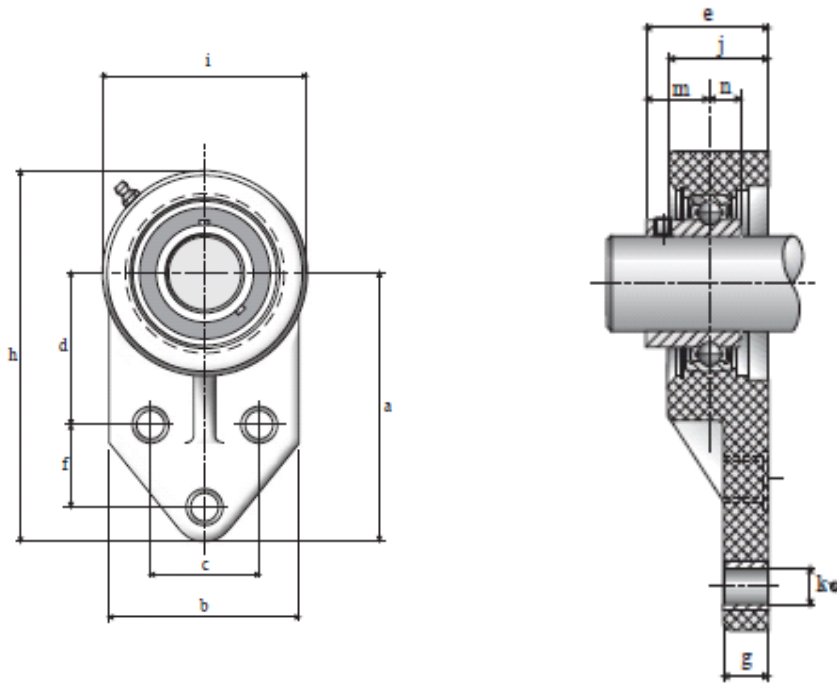

UNIT NUMBER	Bore Dia (mm) d	H	i	d	c	f	e	k $\phi$	Bearing No.	Housing No.
SUCFB201	12	108	63,5	43,3	38,1	22	34,1	10	SUC201	SFB201
SUCFB202	15	108	63,5	43,3	38,1	22	34,1	10	SUC202	SFB202
SUCFB203	17	108	63,5	43,3	38,1	22	34,1	10	SUC203	SFB203
SUCFB204	20	108	63,5	43,3	38,1	22	34,1	10	SUC204	SFB204
SUCFB205	25	121	70	46	41,3	28,5	36,5	10	SUC205	SFB205
SUCFB206	30	137	83	52,4	47,6	31,7	40,9	10	SUC206	SFB206
SUCFB207	35	156	95	60,3	50,8	31,7	46,4	13	SUC207	SFB207
SUCFB208	40	164	100	60,3	50	41,3	51,2	12	SUC208	SFB208
SUCFB209	45	174	106	65	54	42,9	51,2	12	SUC209	SFB209
SUCFB210	50	190	118	74,6	70	41,3	53,6	13	SUC210	SFB210

# SUCFA 200 SERIES STAINLESS STEEL



## TECHNICAL DATA

Our 100% stainless steel units are manufactured from a select grade of stainless steel which has been carefully chosen to give you what you've asked for: optimal corrosion resistance. Bearing life is excellent because it is not limited to the life of the coating and/or nickel plating.

Ring & Balls	S420C
Slinger and Retainer	S420C
Seal	Nitril rubber (NBR)
Housing	S420C
Tolerance	P0 (ABEC1)
Bearing-grease	Mobil FM222 food grease (FDA)

## OPERATING TEMPERATURE RANGE

-20~+120c

Scratchers and mars have absolutely no effect on the bearing's ability to resist rust and corrosion.

Excellent for use in food processing, beverage and other high-corrosive applications, these bearings are 100% stainless throughout: housing, balls, inner and outer races, cages, slingers and set screws.

## Specifications and Approvals: Mobil FM222

Mobilgrease FM meets or exceeds the requirements of:	FM 101	FM 222
FDA 21 CFR 178.3570	X	X
DIN 51825 (2006:06)	KPF1K -20	KPF2K -20
Mobilgrease FM has the following builder approvals:	FM 101	FM 222
MAG IAS, LLC	P-72	P-64
Kosher/Parve	X	X
Halal	X	X
Mobilgrease FM is Registered to the requirement of:	FM 101	FM 222
NSF H1	X	X
NSF Registration Number	141881	136449

## SUCFA 200 SERIES STAINLESS STEEL

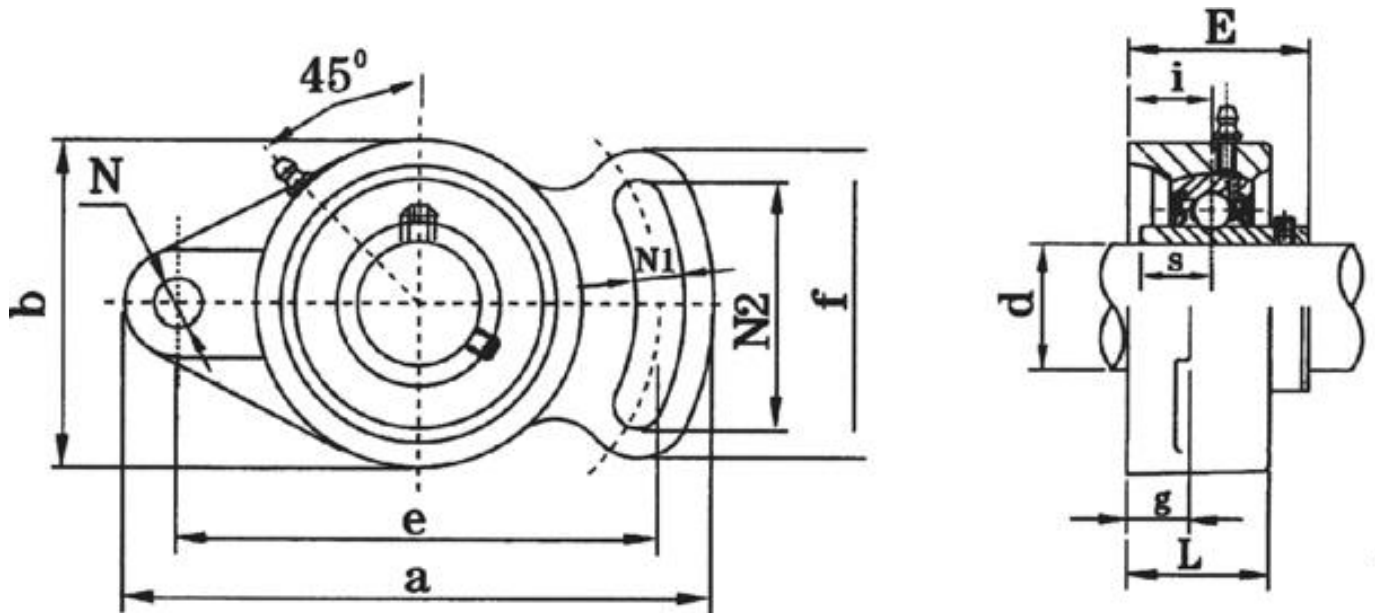

UNIT NUMBER	Bore Dia (mm) d	a	e	b	N1 + N	N2	E	kg	Bearing No.	Housing No.
SUCFA201	12	98	78	60	10	40	33,3	0,48	SUC201	SFA201
SUCFA202	15	98	78	60	10	40	33,3	0,48	SUC202	SFA202
SUCFA203	17	98	78	60	10	40	33,3	0,48	SUC203	SFA203
SUCFA204	20	98	78	60	10	40	33,3	0,45	SUC204	SFA204
SUCFA205	25	125	99	70	13	51	35,8	0,64	SUC205	SFA205
SUCFA206	30	144	117	83	13	58	40,2	0,92	SUC206	SFA206
SUCFA207	35	161	130	96	15	66	44,4	1,27	SUC207	SFA207
SUCFA208	40	175	144	105	15	71	51,2	1,62	SUC208	SFA208
SUCFA209	45	181	148	111	17	72	52,2	1,84	SUC209	SFA209
SUCFA210	50	190	157	116	17	76	54,6	2,10	SUC210	SFA210
SUCFA211	55	219	184	133	17	86	58,4	2,16	SUC211	SFA211

# SUCPPL 200 SERIES THERMOPLASTIC HOUSE

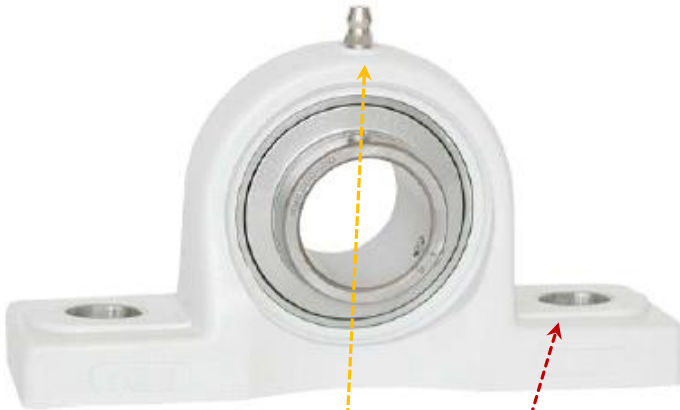

## OTHER COLORS

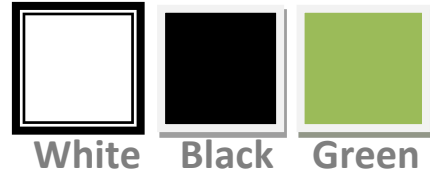

White

Black

Green

## BEARINGS INSERT

Stainless Steel type MUC

Stainless Steel type MB

Steel UC

Steel B

Steel Eccentric UG

Steel UK

## MATERIAL

### Housing

Exclusive PBT

Stainless Steel 304 inserts

Stainless Steel 304 greaser

### Cover

Polypropylen

Stainless Steel ring

## OPTIONS

Close covers

Open covers (with Stainless Steel spring)

Back seals

Plastic covers for grease nipple

Color

## TECHNICAL DATA

No corrosion

FDA&FSDA approval

From 12 to 50 mm

Interchangeable with cast iron standarts units

Maintenance free

Temperature work from - 35 to 102 degree

Tensile strength at break (ASTM 0630) is an impressive 17.300 PSI

Excellent mechanical strength' stiffness & dimension stability

Stainless Steel greasers and inserts

Solid base prevent dirt & bacteria

Reluable

# SUCPPL 200 SERIES THERMOPLASTIC HOUSE

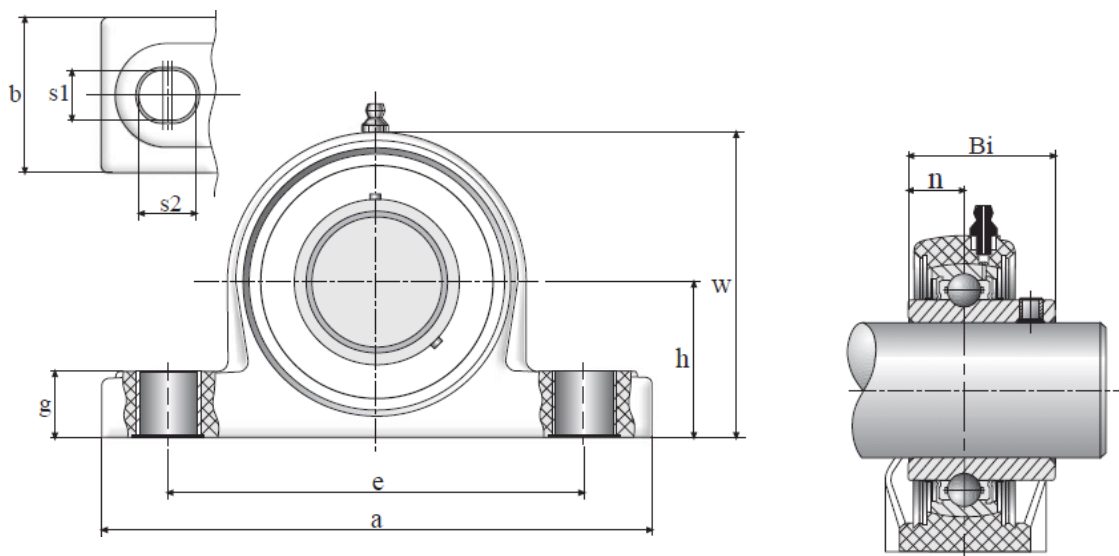

UNIT NUMBER	DKC varenr. på løst hus	Bore Dia (mm) d	h	a	e	b	s1	s2	g	w	Bi	n	bolt
SUCPPL201	P204K	12	33,3	127	95	38	11	14	14,2	65	31	12,7	M10
SUCPPL202	P204K	15	33,3	127	95	38	11	14	14,2	65	31	12,7	M10
SUCPPL203	P204K	17	33,3	127	95	38	11	14	14,2	65	31	12,7	M10
SUCPPL204	P204K	20	33,3	127	95	38	11	14	14,2	65,5	31	12,7	M10
SUCPPL205	P205K	25	36,5	140,5	105	38	11	14	14,5	71	34	14,3	M10
SUCPPL206	P206K	30	42,9	163	119	46	14	18	17,8	84	38,1	15,9	M12
SUCPPL207	P207K	35	47,6	168	127	48	14	18	18	94,5	42,9	17,5	M12
SUCPPL208	P208K	40	49,2	184	137	54	14	18	19,5	99	49,2	19	M12
SUCPPL209	P209K	45	54	192	146	54	17	20	23	106	49,2	19	M16
SUCPPL210	P210K	50	57,2	206	159	60	17	20	23	114	51,6	19	M16

# SUCFPL 200 SERIES THERMOPLASTIC HOUSE



## OTHER COLORS

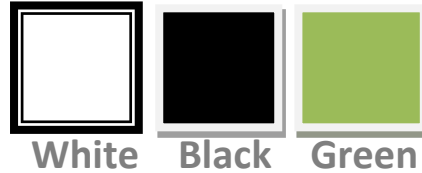

## BEARINGS INSERT

**Stainless Steel type MUC**

**Stainless Steel type MB**

**Steel UC**

**Steel B**

**Steel Eccentric UG**

**Steel UK**

## MATERIAL

### Housing

**Exclusive PBT**

**Stainless Steel 304 inserts**

**Stainless Steel 304 greaser**

### Cover

**Polypropylen**

**Stainless Steel ring**

## OPTIONS

**Close covers**

**Open covers (with Stainless Steel spring)**

**Back seals**

**Plastic covers for grease nipple**

**Color**

## TECHNICAL DATA

**No corrosion**

**FDA&FSDA approval**

**From 12 to 50 mm**

**Interchangeable with cast iron standarts units**

**Maintenance free**

**Temperature work from - 35 to 102 degree**

**Tensile strength at break (ASTM 0630) is an impressive 17.300 PSI**

**Excellent mechanical strength' stiffness & dimension stability**

**Stainless Steel greasers and inserts**

**Solid base prevent dirt & bacteria**

**Reluable**



# SUCFPL 200 SERIES THERMOPLASTIC HOUSE

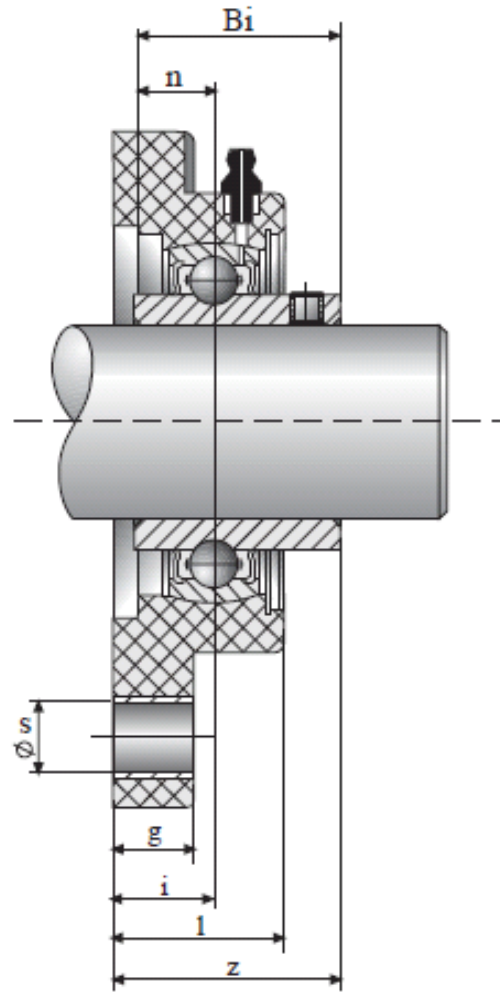
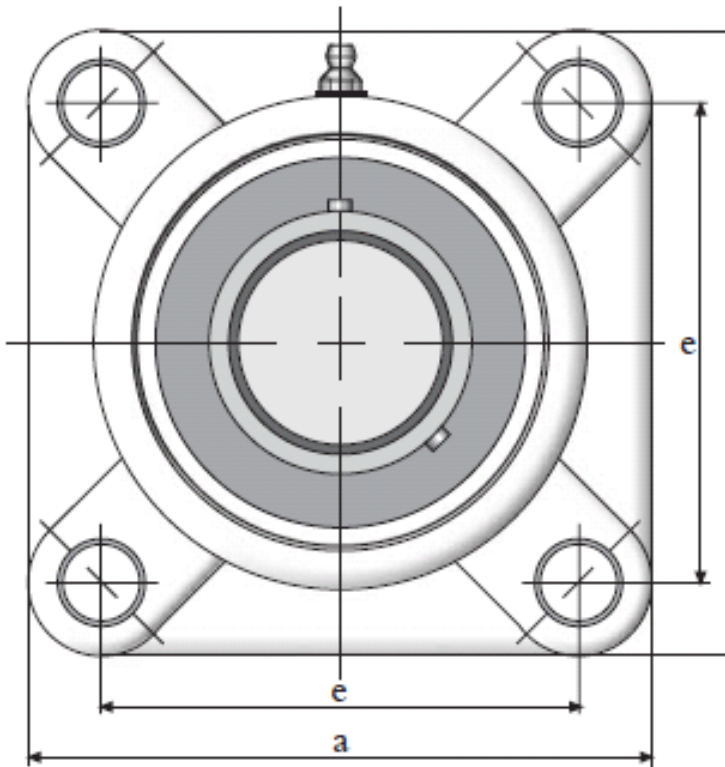

UNIT NUMBER	DKC varenr. på løs flange	Bore Dia (mm) d	a	e	g	l	s	z	i	Bi	n
SUCFPL201	F204K	12	86	63,5	13,4	27,8	11	36,3	18	31	12,7
SUCFPL202	F204K	15	86	63,5	13,4	27,8	11	36,3	18	31	12,7
SUCFPL203	F204K	17	86	63,5	13,4	27,8	11	36,3	18	31	12,7
SUCFPL204	F204K	20	86	63,5	13,4	27,8	11	36,3	18	31	12,7
SUCFPL205	F205K	25	95	70	14	28	11	36,7	17	34	14,3
SUCFPL206	F206K	30	107	83	14,3	31,5	11	41,4	19,2	38,1	15,9
SUCFPL207	F207K	35	118	92	15,5	34,8	13	46,9	21,5	42,9	17,5
SUCFPL208	F208K	40	130	102	17	37,5	14	53,2	23	49,2	19
SUCFPL209	F209K	45	137	105	19	41	17	54,2	24	49,2	19
SUCFPL210	F210K	50	143	111	21	43	17	57,6	25	51,6	19

# SUCNFL 200 SERIES THERMOPLASTIC HOUSE



## OTHER COLORS

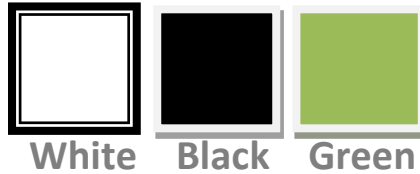

## BEARINGS INSERT

**Stainless Steel type MUC**

**Stainless Steel type MB**

**Steel UC**

**Steel B**

**Steel Eccentric UG**

**Steel UK**

## MATERIAL

### Housing

**Exclusive PBT**

**Stainless Steel 304 inserts**

**Stainless Steel 304 greaser**

### Cover

**Polypropylen**

**Stainless Steel ring**

## OPTIONS

**Close covers**

**Open covers (with Stainless Steel spring)**

**Back seals**

**Plastic covers for grease nipple**

**Color**

## TECHNICAL DATA

**No corrosion**

**FDA&FSDA approval**

**From 12 to 50 mm**

**Interchangeable with cast iron standarts units**

**Maintenance free**

**Temperature work from - 35 to 102 degree**

**Tensile strength at break (ASTM 0630) is an impressive 17.300 PSI**

**Excellent mechanical strength' stiffness & dimension stability**

**Stainless Steel greasers and inserts**

**Solid base prevent dirt & bacteria**

**Reluable**

# SUCNFL 200 SERIES THERMOPLASTIC HOUSE

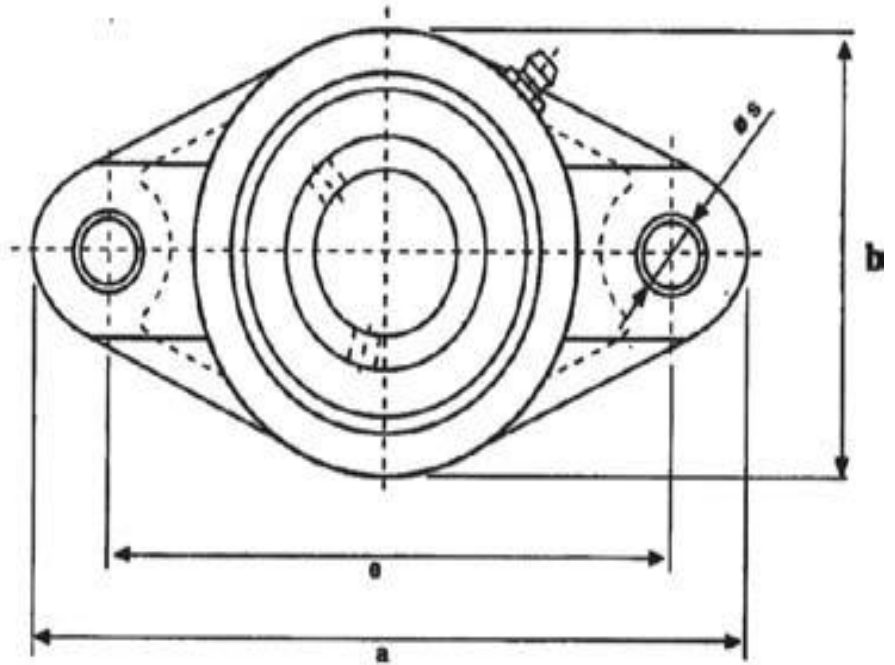
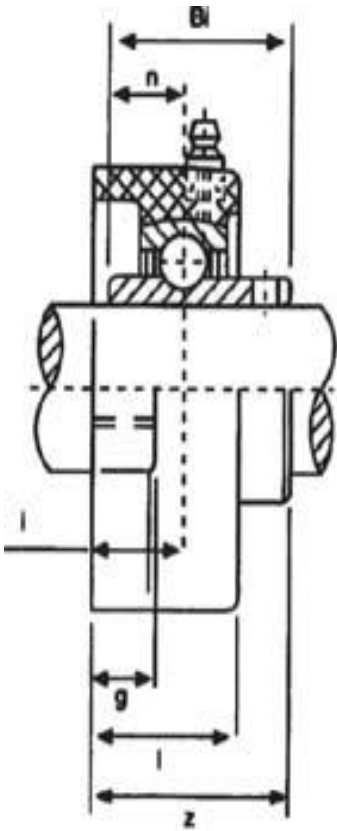

UNIT NUMBER	DKC varenr. på løs flange	Bore Dia (mm) d	a	e	b	g	l	s	z	i	n	Bi
SUCNFL201	FL204K	12	113	90	64	11,4	26,5	11	33,7	15,4	12,7	31
SUCNFL202	FL204K	15	113	90	64	11,4	26,5	11	33,7	15,4	12,7	31
SUCNFL203	FL204K	17	113	90	64	11,4	26,5	11	33,7	15,4	12,7	31
SUCNFL204	FL204K	20	113	90	64	11,4	26,5	11	33,7	15,4	12,7	31
SUCNFL205	FL205K	25	131	99	69,5	13,5	29,1	11	36,7	17	14,3	34
SUCNFL206	FL206K	30	148	117	80	13,3	30,5	11	41,2	19	15,9	38,1
SUCNFL207	FL207K	35	164	130	90	16,1	32,8	13	43,4	18	17,5	42,9
SUCNFL208	FL208K	40	176	144	100	20	37,5	14	51,7	21,5	19	49,2
SUCNFL209	FL209K	45	188	148	108	21	41	17	54,2	24	19	49,2
SUCNFL210	FL210K	50	197	157	115	21	43	17	57,6	25	19	51,6

# SUCFBL 200 SERIES THERMOPLASTIC HOUSE



## OTHER COLORS

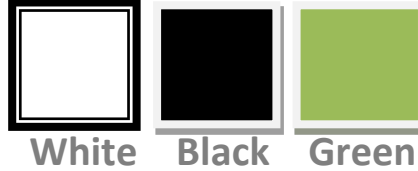

White Black Green

## BEARINGS INSERT

**Stainless Steel type MUC**

**Stainless Steel type MB**

**Steel UC**

**Steel B**

**Steel Eccentric UG**

**Steel UK**

## MATERIAL

### Housing

**Exclusive PBT**

**Stainless Steel 304 inserts**

**Stainless Steel 304 greaser**

### Cover

**Polypropylen**

**Stainless Steel ring**

## OPTIONS

**Close covers**

**Open covers (with Stainless Steel spring)**

**Back seals**

**Plastic covers for grease nipple**

**Color**

## TECHNICAL DATA

**No corrosion**

**FDA&FSDA approval**

**From 12 to 50 mm**

**Interchangeable with cast iron standarts units**

**Maintenance free**

**Temperature work from - 35 to 102 degree**

**Tensile strength at break (ASTM 0630) is an impressive 17.300 PSI**

**Excellent mechanical strength' stiffness & dimension stability**

**Stainless Steel greasers and inserts**

**Solid base prevent dirt & bacteria**

**Reluable**

# SUCFBL 200 SERIES THERMOPLASTIC HOUSE

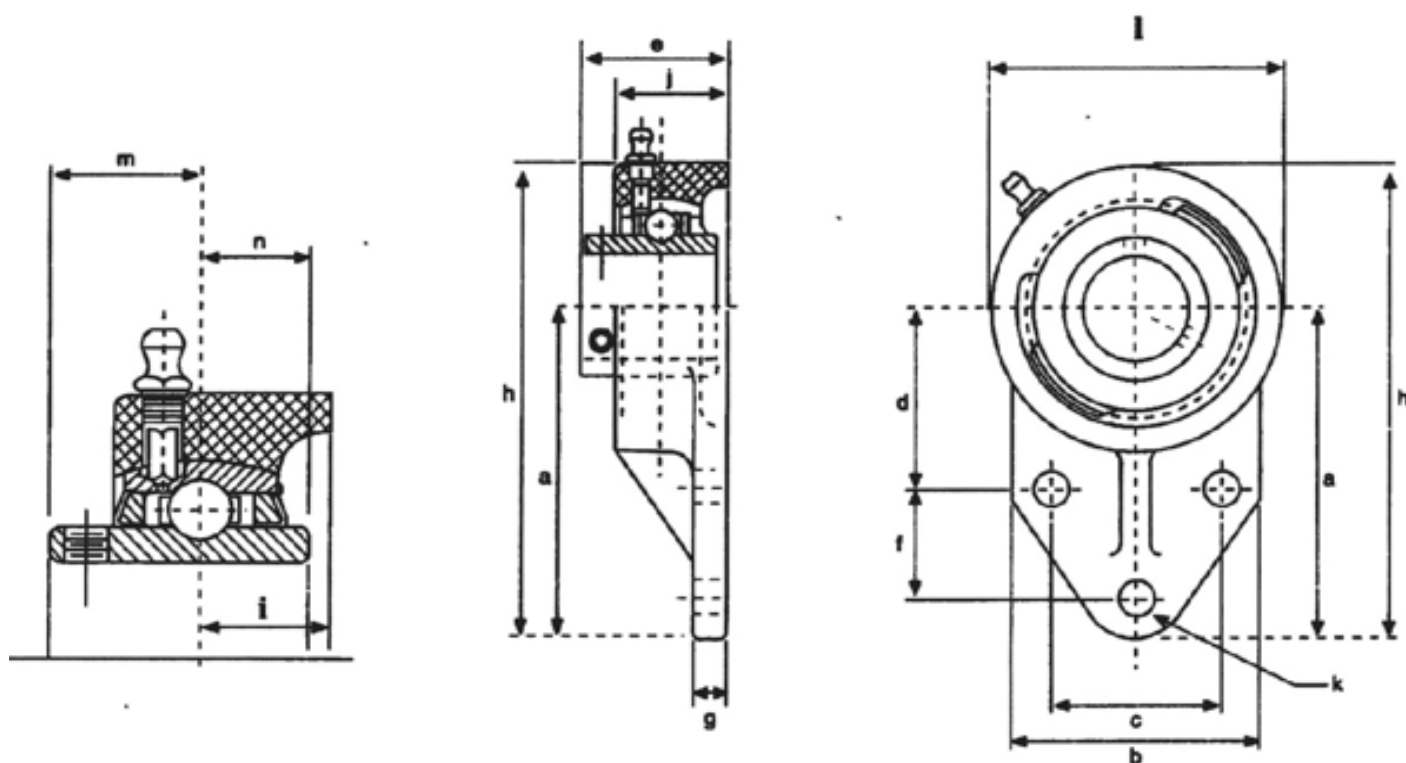

UNIT NUMBER	DKC varenr. på løs flange	Bore Dia (mm) d	a	b	c	d	e	f	g	h	l	k	n
SUCFBL201	FB204K	12	76,2	62	38,1	42,9	33,7	22,2	11,4	108	63,5	10,7	12,7
SUCFBL202	FB204K	15	76,2	62	38,1	42,9	33,7	22,2	11,4	108	63,5	10,7	12,7
SUCFBL203	FB204K	17	76,2	62	38,1	42,9	33,7	22,2	11,4	108	63,5	10,7	12,7
SUCFBL204	FB204K	20	76,2	62	38,1	42,9	33,7	22,2	11,4	108	63,5	10,7	12,7
SUCFBL205	FB205K	25	85,7	63,5	41,3	46	40,7	28,6	11,4	120,6	70	10,7	14,3
SUCFBL206	FB206K	30	95	76	47,6	52,4	41,2	31,8	13,3	138,5	83	10,7	15,9
SUCFBL207	FB207K	35	108	89	50,8	60,3	46,8	31,8	16,1	157	95	13,1	17,5

# SUCHPL 200 SERIES THERMOPLASTIC HOUSE



## OTHER COLORS

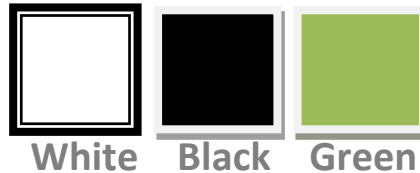

## BEARINGS INSERT

Stainless Steel type MUC

Stainless Steel type MB

Steel UC

Steel B

Steel Eccentric UG

Steel UK

## MATERIAL

### Housing

Exclusive PBT

Stainless Steel 304 inserts

Stainless Steel 304 greaser

### Cover

Polypropylen

Stainless Steel ring

## OPTIONS

Close covers

Open covers (with Stainless Steel spring)

Back seals

Plastic covers for grease nipple

Color

## TECHNICAL DATA

No corrosion

FDA&FSDA approval

From 12 to 50 mm

Interchangeable with cast iron standarts units

Maintenance free

Temperature work from - 35 to 102 degree

Tensile strength at break (ASTM 0630) is an impressive 17.300 PSI

Excellent mechanical strength' stiffness & dimension stability

Stainless Steel greasers and inserts

Solid base prevent dirt & bacteria

Reluable

# SUCHPL 200 SERIES THERMOPLASTIC HOUSE

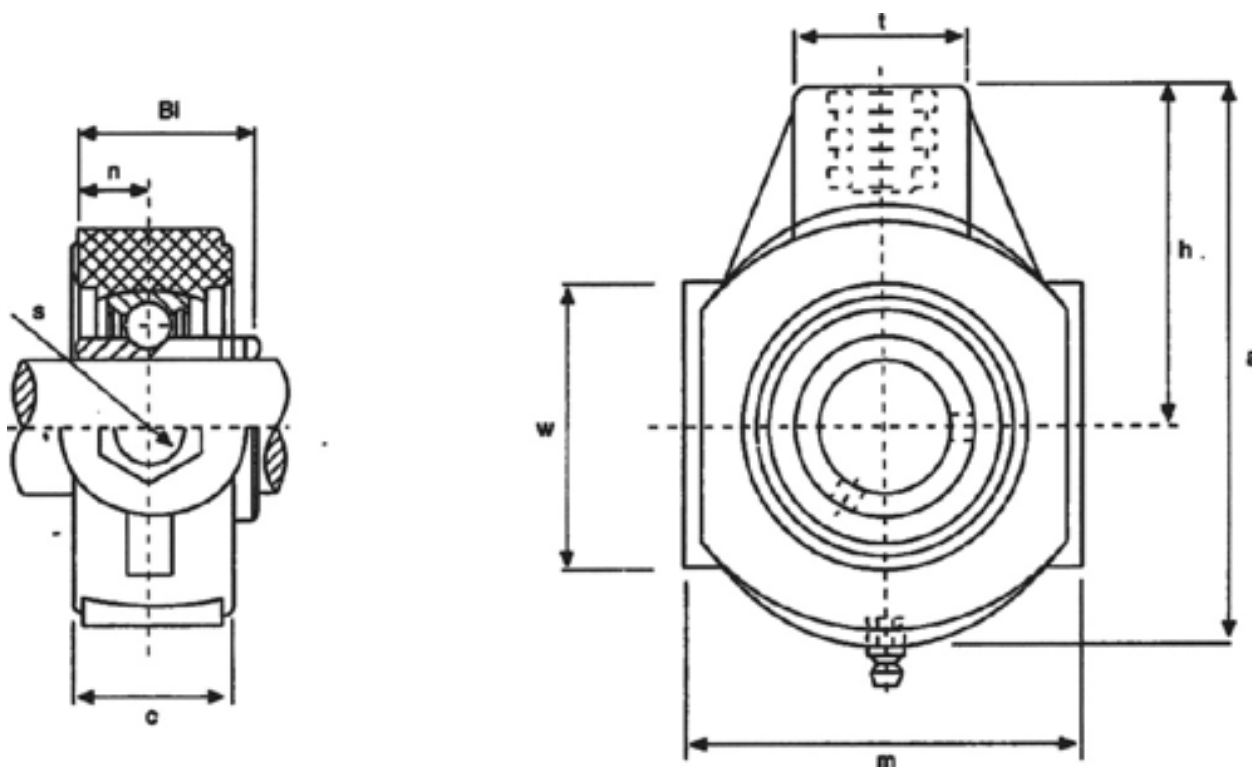

UNIT NUMBER	DKC varenr. på løs flange	Bore Dia (mm) d	a	c	h	m	t	w	Bi	n	Vægt (Kg)	Bolt
SUCHPL201	HPL204K	12	99	27,5	63,5	65	35	47	31	12,7	0,15	M16
SUCHPL202	HPL204K	15	99	27,5	63,5	65	35	47	31	12,7	0,15	M16
SUCHPL203	HPL204K	17	99	27,5	63,5	65	35	47	31	12,7	0,15	M16
SUCHPL204	HPL204K	20	99	27,5	63,5	65	35	47	31	12,7	0,15	M16
SUCHPL205	HPL205K	25	99	27,5	63,5	74	35	47	34	14,3	0,16	M16
SUCHPL206	HPL206K	30	125	34,5	76	90	40	63	38,1	15,9	0,21	M16
SUCHPL207	HPL207K	35	125	34,5	76	90	40	63	42,9	17,5	0,25	M16
SUCHPL208	HPL208K	40	140	38,5	85	100	46	80	49,2	19	0,36	M16
SUCHPL209	HPL209K	45	149	40	90	110	50	85	49,2	19	0,45	M20
SUCHPL210	HPL210K	50	149	40	90	110	50	85	51,6	19	0,49	M20

# SUCTPL 200 SERIES THERMOPLASTIC HOUSE



## OTHER COLORS

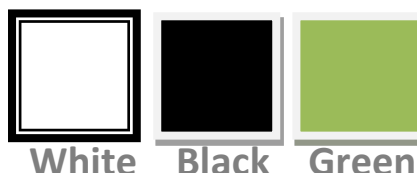

## BEARINGS INSERT

**Stainless Steel type MUC**

**Stainless Steel type MB**

**Steel UC**

**Steel B**

**Steel Eccentric UG**

**Steel UK**

## MATERIAL

### Housing

**Exclusive PBT**

**Stainless Steel 304 inserts**

**Stainless Steel 304 greaser**

### Cover

**Polypropylen**

**Stainless Steel ring**

## OPTIONS

**Close covers**

**Open covers (with Stainless Steel spring)**

**Back seals**

**Plastic covers for grease nipple**

**Color**

## TECHNICAL DATA

**No corrosion**

**FDA&FSDA approval**

**From 12 to 50 mm**

**Interchangeable with cast iron standarts units**

**Maintenance free**

**Temperature work from - 35 to 102 degree**

**Tensile strength at break (ASTM 0630) is an impressive 17.300 PSI**

**Excellent mechanical strength' stiffness & dimension stability**

**Stainless Steel greasers and inserts**

**Solid base prevent dirt & bacteria**

**Reluable**



# SUCTPL 200 SERIES THERMOPLASTIC HOUSE

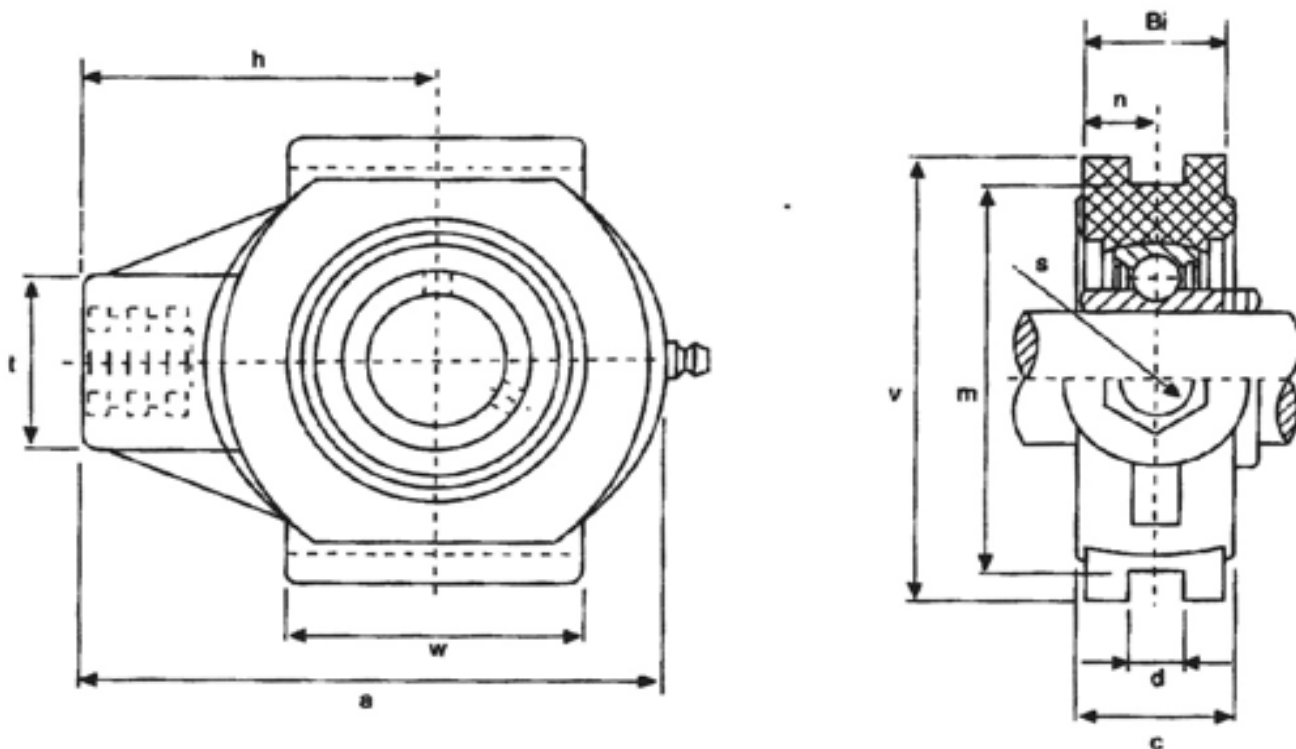

UNIT NUMBER	DKC varenr. på løs flange	Bore Dia (mm) d	a	c	d	h	m	t	v	w	Bi	n	Vægt (Kg)	Bolt
SUCTPL201	TPL204K	12	99	27,5	12	64	76	35	88	47	31	12,7	0,16	M16
SUCTPL202	TPL204K	15	99	27,5	12	64	76	35	88	47	31	12,7	0,16	M16
SUCTPL203	TPL204K	17	99	27,5	12	64	76	35	88	47	31	12,7	0,16	M16
SUCTPL204	TPL204K	20	99	27,5	12	64	76	35	88	47	31	12,7	0,16	M16
SUCTPL205	TPL205K	25	99	27,5	12	64	76	35	88	47	34	14,3	0,17	M16
SUCTPL206	TPL206K	30	125	34,5	12	76	89	40	102	63	38,1	15,9	0,22	M16
SUCTPL207	TPL207K	35	125	34,5	12	76	89	40	102	63	42,9	17,5	0,26	M16
SUCTPL208	TPL208K	40	140	38,5	16	85	102	46	114	80	49,2	19	0,38	M16
SUCTPL209	TPL209K	45	149	40	16	90	102	50	117	85	49,2	19	0,48	M20
SUCTPL210	TPL210K	50	149	40	16	90	102	50	117	85	51,6	19	0,52	M20

# SUCTBL 200 SERIES THERMOPLASTIC HOUSE



## OTHER COLORS

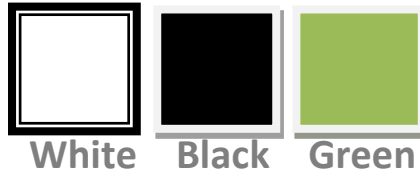

White Black Green

## BEARINGS INSERT

**Stainless Steel type MUC**

**Stainless Steel type MB**

**Steel UC**

**Steel B**

**Steel Eccentric UG**

**Steel UK**

## MATERIAL

### Housing

**Exclusive PBT**

**Stainless Steel 304 inserts**

**Stainless Steel 304 greaser**

### Cover

**Polypropylen**

**Stainless Steel ring**

## OPTIONS

**Close covers**

**Open covers (with Stainless Steel spring)**

**Back seals**

**Plastic covers for grease nipple**

**Color**

## TECHNICAL DATA

**No corrosion**

**FDA&FSDA approval**

**From 12 to 50 mm**

**Interchangeable with cast iron standarts units**

**Maintenance free**

**Temperature work from - 35 to 102 degree**

**Tensile strength at break (ASTM 0630) is an impressive 17.300 PSI**

**Excellent mechanical strength' stiffness & dimension stability**

**Stainless Steel greasers and inserts**

**Solid base prevent dirt & bacteria**

**Reluable**

# SUCTBL 200 SERIES THERMOPLASTIC HOUSE

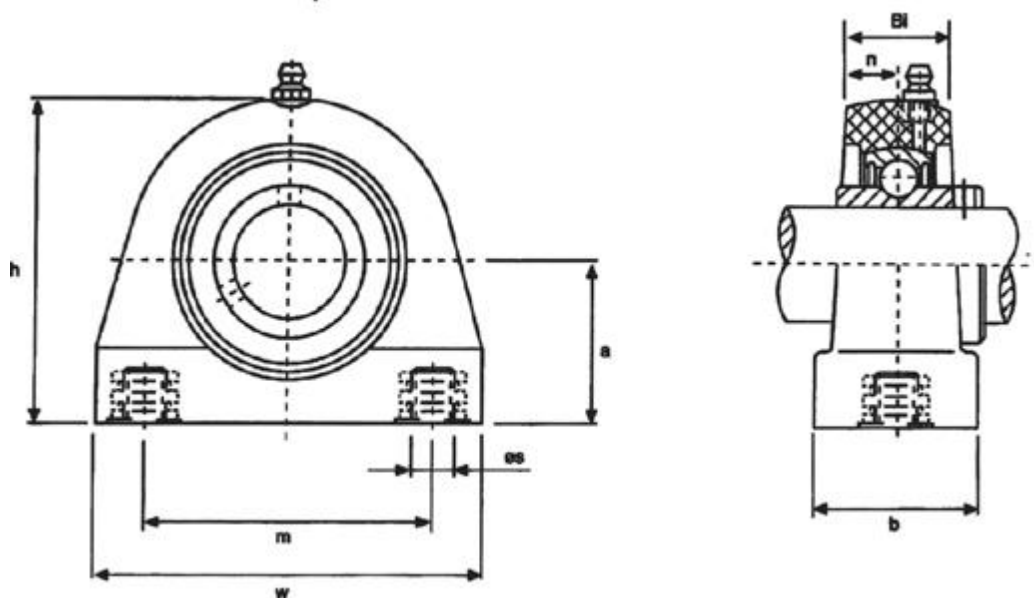

UNIT NUMBER	DKC varenr. på løsT hus	Bore Dia (mm) d	a	b	h	m	w	Bi	N	Vægt (Kg)	bolt
SUCTBL201	PA204K	12	33,3	34,5	66	50,8	72,8	31	12,7	0,13	M8
SUCTBL202	PA204K	15	33,3	34,5	66	50,8	72,8	31	12,7	0,13	M8
SUCTBL203	PA204K	17	33,3	34,5	66	50,8	72,8	31	12,7	0,13	M8
SUCTBL204	PA204K	20	33,3	34,5	66	50,8	72,8	31	12,7	0,13	M8
SUCTBL205	PA205K	25	36,5	39,5	73,5	50,8	76,2	34	14,3	0,15	M10
SUCTBL206	PA206K	30	42,9	42,5	84	76,2	101	38,1	15,9	0,24	M10
SUCTBL207	PA207K	35	47,6	47,5	95	82,6	110	42,9	17,5	0,28	M10
SUCTBL208	PA208K	40	49,2	48	100,5	88,9	120	49,2	19	0,39	M12
SUCTBL209	PA209K	45	54	54	107	95,3	124	49,2	19	0,47	M12
SUCTBL210	PA210K	50	57,2	54	115	101,6	135	51,6	19	0,56	M16

# THERMOPLASTIC UNITS COVERS



## END COVERS

Polypropylene end covers are available to fit all ANB units.

End covers can be used at temperatures ranging from  $-20^{\circ}\text{C}$  to  $-90^{\circ}\text{C}$ .

They must be used as additional protection for the bearing in adverse environmental conditions as well as an aid to meeting safety requirements.

They are available in close or open version ( with stainless steel spring)

Designed to meet the needs of the wastewater treatment plants, gyp-sum manufacturers and the wood, paper and pulp industries this superior bearing protection system keeps contaminants out while it keeps lubricants in.

## Capilene ® SR 50

Polypropylene Impact Copolymer

## DESCRIPTION

Capilene SR 50 is a medium flow impact copolymer grade, featuring:

- \* Good balance between flow and mechanical properties.
- \* Good processability.
- \* Good impact resistance.

# STAINLESS STEEL BEARING INSERT SSUC200 SERIES



Ring & Balls	S420C
Slinger and Retainer	S420C
Seal	Nitril rubber (NBR)
Tolerance	P0 (ABEC1)
Bearing-grease	Mobil FM222 food grease (FDA)

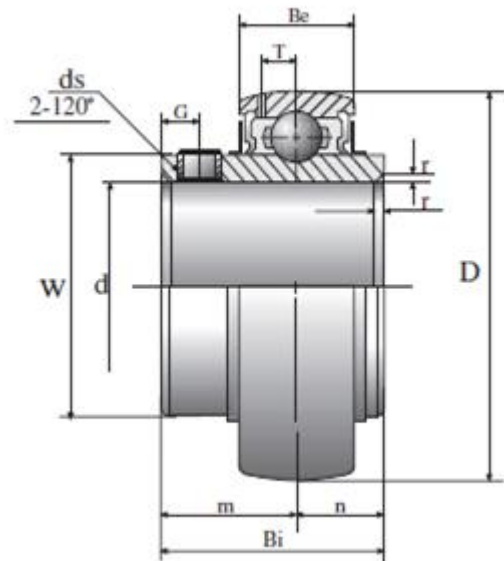

BEARING NUMBER	DIMENSIONS (mm)							BASIC LOAD RATINGS (kN)	
	Bore Dia (mm) d	D	Bi	Be	N	M	G	Basic load Rating	Basic static rating
SSUC201	12	47	31	17	12,7	18,3	4,7	10,37	5,08
SSUC202	15	47	31	17	12,7	18,3	4,7	10,37	5,08
SSUC203	17	47	31	17	12,7	18,3	4,7	10,37	5,08
SSUC204	20	47	31	17	12,7	18,3	4,7	10,37	5,08
SSUC205	25	52	34,1	17	14,3	19,8	5	11,31	6,00
SSUC206	30	62	38,1	19	15,9	22,2	5	15,81	8,64
SSUC207	35	72	42,9	20	17,5	25,4	6	20,83	11,68
SSUC208	40	80	49,2	21	19	30,2	8	23,55	13,60
SSUC209	45	85	49,2	22	19	30,2	8	26,35	15,60
SSUC210	50	90	51,6	24	19	32,6	10	28,48	18
SSUC211	55	100	55,6	25	22,2	33,4	10	35,28	22,4
SSUC212	60	110	65,1	27	25,4	39,7	10	42,50	26,34
SSUC213	65	120	65,1	28	25,4	39,7	10	46,50	30,4
SSUC214	70	125	74,6	30	30,2	44,4	12	50,15	33,6
SSUC215	75	130	77,8	32	33,3	44,5	12	53,55	37,6
SSUC216	80	140	82,6	33	33,3	49,3	14	58,65	40,8
SSUC217	85	150	85,7	35	34,1	51,6	14	68,00	48,8
SSUC218	90	160	96	37	39,7	56,3	15	77,52	54,56

# STAINLESS STEEL BEARING INSERT SSA200 SERIES



Ring & Balls	S420C
Slinger and Retainer	S420C
Seal	Nitril rubber (NBR)
Tolerance	P0 (ABEC1)
Bearing-grease	Mobil FM222 food grease (FDA)

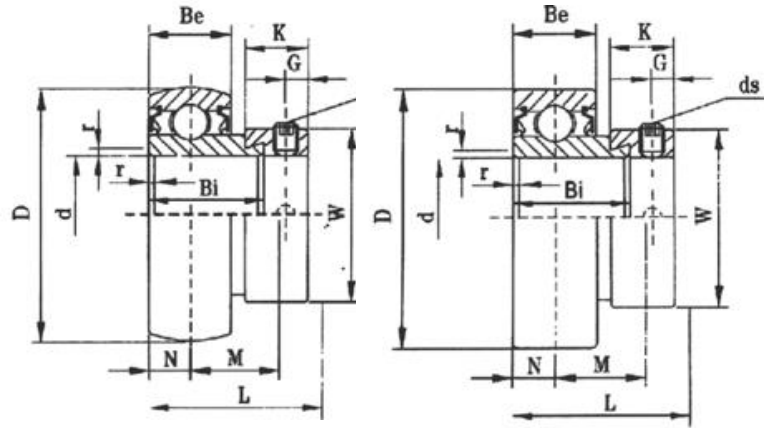

BEARING NUMBER	DIMENSIONS (mm)							BASIC LOAD RATINGS (kN)	
	Bore Dia (mm) d	D	Bi	Be	L	W	K	Dyn	static
SSA201	12	40	19,1	12	28,6	28,6	13,5	7,84	3,58
SSA202	15	40	19,1	12	28,6	28,6	13,5	7,84	3,58
SSA203	17	40	19,1	12	28,6	28,6	13,5	7,84	3,58
SSA204	20	47	21,5	14	31	33,3	13,5	10,37	5,04
SSA205	25	52	21,5	15	31	38,1	13,5	11,31	5,97
SSA206	30	62	23,8	16	35,7	44,5	15,9	15,73	8,64
SSA207	35	72	25,4	17	38,9	55,6	17,5	20,83	11,68
SSA208	40	80	30,2	18	43,7	60,3	18,3	23,55	13,6
SSA209	45	85	30,2	19	43,7	63,5	18,3	26,44	19,56
SSA210	50	90	30,2	20	43,7	69,9	18,3	30,01	22,53
SSA211	55	100	32,5	21	48,4	76,2	20,7	32,39	24
SSA212	60	110	37,1	22	53,1	84,2	22,3	35,28	26,18

# STAINLESS STEEL BEARING INSERT SSB200 SERIES

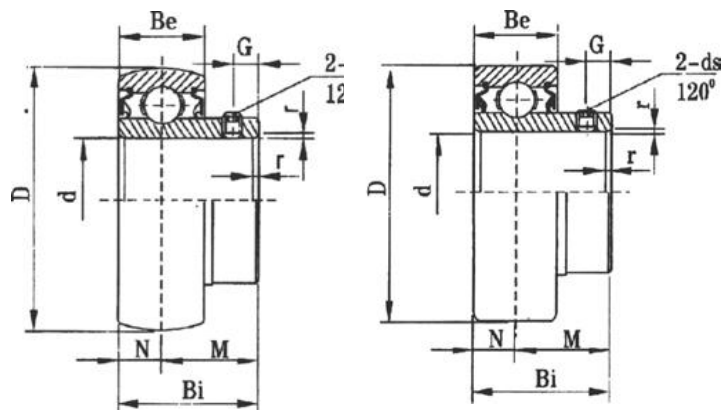

Ring & Balls	S420C
Slinger and Retainer	S420C
Seal	Nitril rubber (NBR)
Tolerance	P0 (ABEC1)
Bearing-grease	Mobil FM222 food grease (FDA)

BEARING NUMBER	DIMENSIONS (mm)							BASIC LOAD RATINGS (kN)	
	Bore Dia (mm) d	D	Bi	N	M	G	ds	Dyn	static
SSB201	12	40	22	6	16	4,5	M5X0,8	7,82	3,58
SSB202	15	40	22	6	16	4,5	M5X0,8	7,82	3,58
SSB203	17	40	22	6	16	4,5	M5X0,8	7,82	3,58
SSB204	20	47	25	7	18	4,5	M6X0,75	10,37	5,04
SSB205	25	52	27	7,5	19,5	5	M6X0,75	11,31	5,97
SSB206	30	62	30	8	22	5,5	M6X0,75	15,73	8,64
SSB207	35	72	32	8,5	23,5	6	M8X1	20,83	11,68
SSB208	40	80	34	9	25	8	M8X1	23,55	13,6
SSB209	45	85	41,2	10,2	31	8	M8X1	26,44	19,56
SSB210	50	90	43,5	10,9	32,6	9	M8X1	30,01	22,53
SSB211	55	100	45,3	11,8	33,5	10	M10X1,25	32,39	24
SSB212	60	110	53,7	14,9	38,8	10	M10X1,25	35,28	26,18

# STAINLESS STEEL RADIAL BEARING SS6000 SERIES

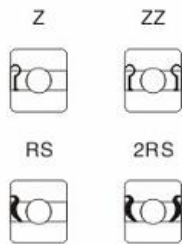
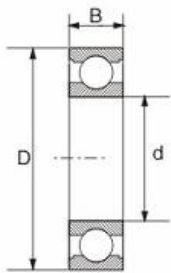

Ring & Balls	S420C
Slinger and Retainer	S420C
Seal	Nitril rubber (NBR)
Tolerance	P0 (ABEC1)
Bearing-grease	Mobil FM222 food grease (FDA)

Bearing NO.	I.D		O.D		W		Load Rating (kgf)		Max Speed	Weight Kg
	d	D	B	Dynamic	Static	Grease				
	mm	inch	mm	Cr	Cor	r/min				
SS6000	10	0.3937	26	1.0236	8	0.315	386	157	29000	0.019
SS6001	12	0.4724	28	1.1024	8	0.315	434	191	26000	0.022
SS6002	15	0.5906	32	1.2598	9	0.3543	475	227	22000	0.030
SS6003	17	0.6693	35	1.378	10	0.3937	509	263	20000	0.039
SS6004	20	0.7874	42	1.6535	12	0.4724	796	405	18000	0.069
SS6005	25	0.9843	47	1.8504	12	0.4724	855	469	15000	0.080
SS6006	30	1.1811	55	2.1645	13	0.5118	1124	661	13000	0.120
SS6007	35	1.3779	62	2.4409	14	0.5512	1356	825	12000	0.160
SS6008	40	1.5748	68	2.6772	15	0.5906	1425	922	10000	0.190
SS6009	45	1.7716	75	2.9528	16	0.6299	1515	966	9200	0.250
SS6010	50	1.965	80	3.1496	16	0.6299	1851	1326	8400	0.260
SS6011	55	2.1653	90	3.5433	18	0.7087				
SS6012	60	2.362	95	3.74	18	0.7087				
SS6013	65	2.559	100	3.937	18	0.7087				
SS6014	70	2.7559	110	4.3307	20	0.7874				
SS6015	75	2.9528	115	4.5276	20	0.7874				
SS6016	80	3.1496	125	4.9213	22	0.8661				
SS6017	85	3.3465	130	5.1181	22	0.8661				
SS6018	90	3.5433	140	5.5118	24	0.9449				
SS6019	95	3.7402	145	5.7087	24	0.9449				
SS6020	100	3.937	150	5.9055	24	0.9449				



# STAINLESS STEEL RADIAL BEARING SS6000 SERIES

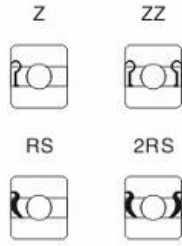
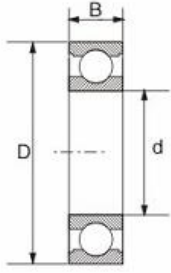

Ring & Balls	S420C
Slinger and Retainer	S420C
Seal	Nitril rubber (NBR)
Tolerance	P0 (ABEC1)
Bearing-grease	Mobil FM222 food grease (FDA)

Bearing NO.	I.D		O.D		W		Load Rating(kgf)		Max Speed	Weight Kg
	d		D		B		Dynamic	Static	Grease	
	mm	inch	mm	inch	mm	inch	Cr	Cor	r/min	
SS6200	10	0.3973	30	1.1811	9	0.3543	434	192	25000	0.032
SS6201	12	0.4724	32	1.2598	10	0.3937	577	245	22000	0.037
SS6202	15	0.5906	35	1.3779	11	0.4331	649	300	19000	0.045
SS6203	17	0.6693	40	1.5748	12	0.4724	813	385	18000	0.065
SS6204	20	0.7874	47	1.8504	14	0.5512	1091	536	16000	0.110
SS6205	25	0.9843	52	2.0472	15	0.5906	1190	630	13000	0.130
SS6206	30	1.1811	62	2.4409	16	0.6299	1653	908	11000	0.200
SS6207	35	1.3779	72	2.8346	17	0.6693	2181	1236	9800	0.290
SS6208	40	1.5748	80	3.1496	18	0.7087	2473	1433	8700	0.370
SS6209	45	1.7716	85	3.3465	19	0.748	2779	1630	7800	0.410
SS6210	50	1.965	90	3.5433	20	0.7841	2980	1861	7100	0.460
SS6211	55	2.1653	100	3.937	21	0.8268				
SS6212	60	2.362	110	4.3307	22	0.8661				
SS6213	65	2.559	120	4.7244	23	0.9055				
SS6214	70	2.7559	125	4.9213	24	0.9449				
SS6215	75	2.9528	130	5.1181	25	0.9843				
SS6216	80	3.1496	140	5.7087	26	1.0236				
SS6217	85	3.3465	150	5.9055	28	1.1024				
SS6218	90	3.5433	160	6.2992	30	1.1811				
SS6219	95	3.7402	170	6.6929	32	1.2598				
SS6220	100	3.937	180	7.0866	34	1.3386				

# STAINLESS STEEL RADIAL BEARING SS6300 SERIES

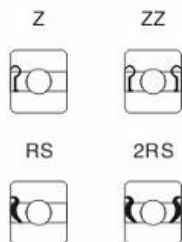
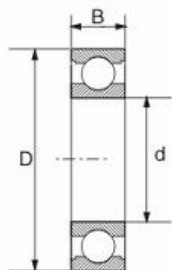

Ring & Balls	S420C
Slinger and Retainer	S420C
Seal	Nitril rubber (NBR)
Tolerance	P0 (ABEC1)
Bearing-grease	Mobil FM222 food grease (FDA)

Bearing NO.	I.D		O.D		W		Load Rating(kgf)		Max Speed	Weight Kg
	d		D		B		Dynamic	Static	Grease	
	mm	inch	mm	inch	mm	inch	Cr	Cor	r/min	
SS6300	10	0.3937	35	1.3779	11	0.4331	687	275	23000	0.053
SS6301	12	0.4724	37	1.4567	12	0.4724	824	336	20000	0.060
SS6302	15	0.5906	42	1.6535	13	0.5118	971	437	17000	0.082
SS6303	17	0.6693	47	1.8504	14	0.5512	1155	533	16000	0.120
SS6304	20	0.7874	52	2.0472	15	0.5906	1349	631	14000	0.140
SS6305	25	0.9843	62	2.4409	17	0.6693	1749	906	12000	0.230
SS6306	30	1.1811	72	2.8346	19	0.748	2263	1208	10000	0.350
SS6307	35	1.3779	80	3.1496	21	0.8268				
SS6308	40	1.5748	90	3.5433	23	0.9055				
SS6309	45	1.7716	100	3.937	25	0.9843				
SS6310	50	1.965	110	4.3307	27	1.063				
SS6311	55	2.1653	120	4.7244	29	1.1417				
SS6312	60	2.362	130	5.1181	31	1.2205				
SS6313	65	2.559	140	5.7087	33	1.2992				
SS6314	70	2.7559	150	5.9055	35	1.378				
SS6315	75	2.9528	160	6.2992	37	1.4567				
SS6316	80	3.1496	170	6.6929	39	1.5354				
SS6317	85	3.3465	180	7.0866	41	1.6142				
SS6318	90	3.5433	190	7.4803	43	1.6929				
SS6319	95	3.7402	200	7.874	45	1.7717				
SS6320	100	3.937	215	8.2677	47	1.8504				

# STAINLESS STEEL RADIAL BEARING SS6800 SERIES

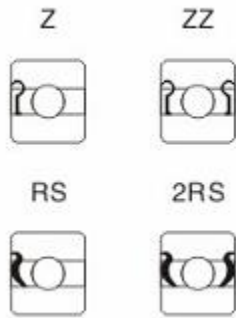
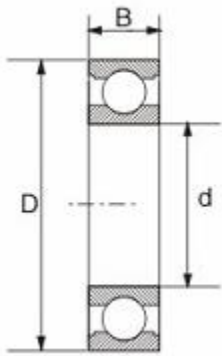

Ring & Balls	S420C
Slinger and Retainer	S420C
Seal	Nitril rubber (NBR)
Tolerance	P0 (ABEC1)
Bearing-grease	Mobil FM222 food grease (FDA)

SS68.. = SS618.. (eks. SS6805-2RS = SS61805-2RS)

Bearing NO.	I.D		O.D		W		Load Rating (kgf)		Max Speed	Weight Kg
	d		D		B		Dynamic	Static	Grease	
	mm	inch	mm	inch	mm	inch	Cr	Cor	r/min	
SS6800	10	0.3937	19	0.748	5	0.1969	147	67	28000	0.005
SS6801	12	0.4724	21	0.8268	5	0.1969	160	87	24000	0.006
SS6802	15	0.5906	24	0.9449	5	0.1969	176	101	22000	0.007
SS6803	17	0.6693	26	1.0236	5	0.1969	186	115	20000	0.008
SS6804	20	0.7874	32	1.2598	7	0.2756	338	195	18000	0.019
SS6805	25	0.9843	37	1.4567	7	0.2756	362	231	16000	0.022
SS6806	30	1.1811	42	1.6535	7	0.2756	387	231	13000	0.026
SS6807	35	1.378	47	1.8504	7	0.2756	399	305	11000	0.029
SS6808	40	1.5748	52	2.0472	7	0.2756	418	332	10000	0.033
SS6809	45	1.7716	58	2.2834	7	0.2756	524	431	9000	0.040
SS6810	50	1.9685	65	2.559	7	0.2756	550	461	8500	0.052

# STAINLESS STEEL RADIAL BEARING SS6900 SERIES

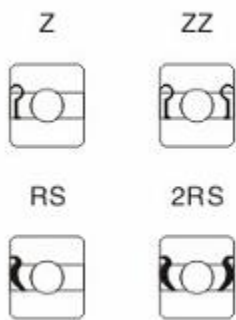
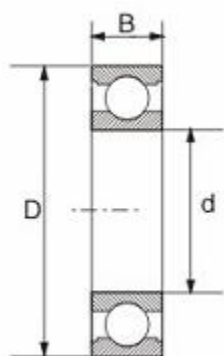

Ring & Balls	S420C
Slinger and Retainer	S420C
Seal	Nitril rubber (NBR)
Tolerance	P0 (ABEC1)
Bearing-grease	Mobil FM222 food grease (FDA)

SS69.. = SS619.. (eks. SS6905-2RS = SS61905-2RS)

Bearing NO.	I.D		O.D		W		Load Rating (KN)		Max Speed	Weight Kg
	d		D		B		Dynamic	Static	Grease	
	mm	inch	mm	inch	mm	inch	Cr	Cor	r/min	
6900	10	0.3937	22	0.8661	6	0.2362	229	102	25000	0.009
6901	12	0.4724	24	0.9449	6	0.2362	245	117	22000	0.011
6902	15	0.5906	28	1.1024	7	0.2362	364	178	20000	0.016
6903	17	0.6693	30	1.1811	7	0.2362	385	205	19000	0.018
6904	20	0.7874	37	1.4567	9	0.3543	533	291	17000	0.036
6905	25	0.9843	42	1.6535	9	0.3543	586	358	14000	0.042
6906	30	1.1811	47	1.8504	9	0.3543	613	399	12000	0.048
6907	35	1.3779	55	2.1653	10	0.3937	926	624	10000	0.074
6908	40	1.5748	62	2.4409	12	0.4724	1154	794	9500	0.110
6909	45	1.7716	68	2.6771	12	0.4724	1173	866	8500	0.128
6910	50	1.9685	72	2.8346	12	0.4724	1199	882	8000	0.132

# STAINLESS STEEL MINIATURE FLANGE-BEARING MUFL



Ring & Balls	S420C
Slinger and Retainer	S420C
Seal	Nitril rubber (NBR)
Tolerance	P0 (ABEC1)
Bearing-grease	Mobil FM222 food grease (FDA)

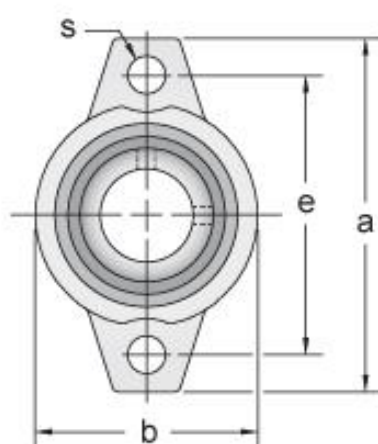

Bore Dia (mm) d	Unit No.	Dimensions (mm)					
		a	e	s	b	Z	L
-----							
10	MUFL000	60	45	7	36	19	17,5
12	MUFL001	63	48	7	38	19	17,5
15	MUFL002	67	53	7	42	20,5	18,5
17	MUFL003	71	56	7	46	22,5	20,5
20	MUFL004	90	71	10	55	26,5	24,5
25	MUFL005	95	75	10	60	27,5	25,5
30	MUFL006	112	85	13	70	29	26,5

# STAINLESS STEEL MINIATURE PILLOW BLOCK-BEARING UNIT MUP



Ring & Balls	S420C
Slinger and Retainer	S420C
Seal	Nitril rubber (NBR)
Tolerance	P0 (ABEC1)
Bearing-grease	Mobil FM222 food grease (FDA)

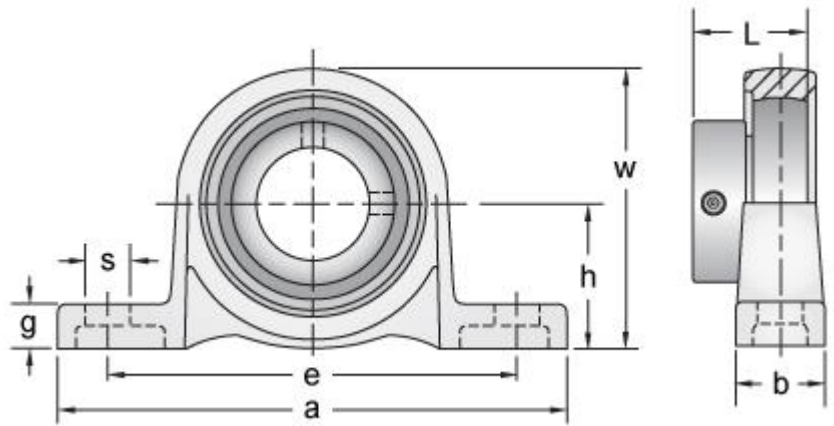

Bore Dia (mm) d	Unit No.	Dimensions (mm)							
		h	a	e	b	s	g	w	L
-----									
10	MUP000	18	67	53	16	7	6	35	17,5
12	MUP001	19	71	56	16	7	6	38	17,5
15	MUP002	22	80	63	16	7	7	43	18,5
17	MUP003	24	85	67	18	7	7	47	20,5
20	MUP004	28	100	80	20	10	9	55	24,5
25	MUP005	32	112	90	20	10	10	62	25,5
30	MUP006	36	132	106	26	13	11	70	26,5

# STAINLESS STEEL MINIATURE BEARING INSERT SU000 MU000

Ring & Balls	S420C
Slinger and Retainer	S420C
Seal	Nitril rubber (NBR)
Tolerance	P0 (ABEC1)
Bearing-grease	Mobil FM222 food grease (FDA)

- Eccentric Collar Locking
- Nylon Retainer
- Contact Seal
- Spherical O.D.
- Prelubricated / Non-relubricatable

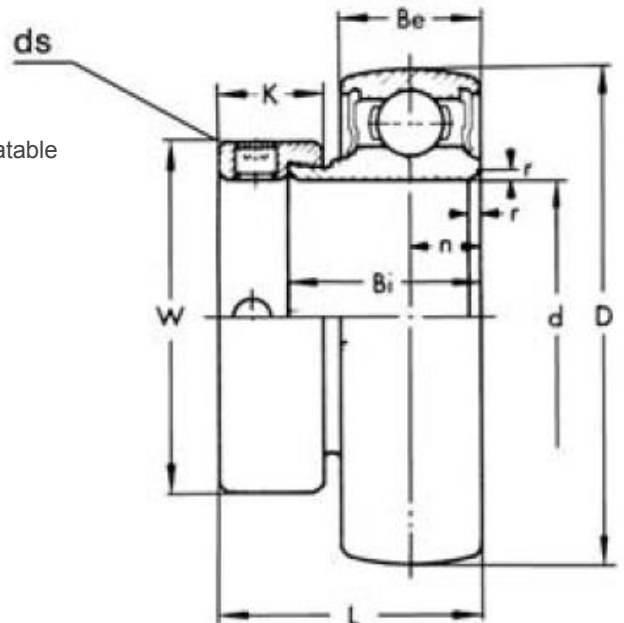

Bearing no.	d mm	D mm	L mm	Bi mm	Be mm	r mm	n mm	k mm	W mm	ds mm	Load Rating dyn.C kN	Load Rating stat.C0 kN	Speed Limit RPM	weight kg
SU000 MU000	10	26	17,5	11	8	0,5	4	8,5	17	M4x0,7	4,00	1,60	13000	0,030
SU001 MU001	12	28	17,5	11	8	0,5	4	8,5	19	M4x0,7	4,40	1,95	10800	0,036
SU002 MU002	15	32	18,5	12	9	0,5	4,5	8,5	22	M4x0,7	4,85	2,30	8600	0,050
SU003 MU003	17	35	20,5	13,5	10	0,5	5	9,5	25	M4x0,7	5,20	2,70	7600	0,062
SU004 MU004	20	42	24,5	16,5	12	1	6	11	30	M5x0,8	8,10	4,10	6500	0,104
SU005 MU005	25	47	25,5	17,5	12	1	6	12	36	M5x0,8	8,75	4,75	5200	0,133
SU006 MU006	30	55	26,5	18,5	13	1,5	6,5	12	42	M5x0,8	11,50	6,75	4300	0,186